

高度 序号	H 高度 mm
A	9.4±0.1(推荐)
B	9.0±0.1
C	10.1±0.1
D	11.5±0.1

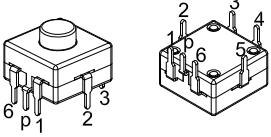

**PBS-07-317-P7**

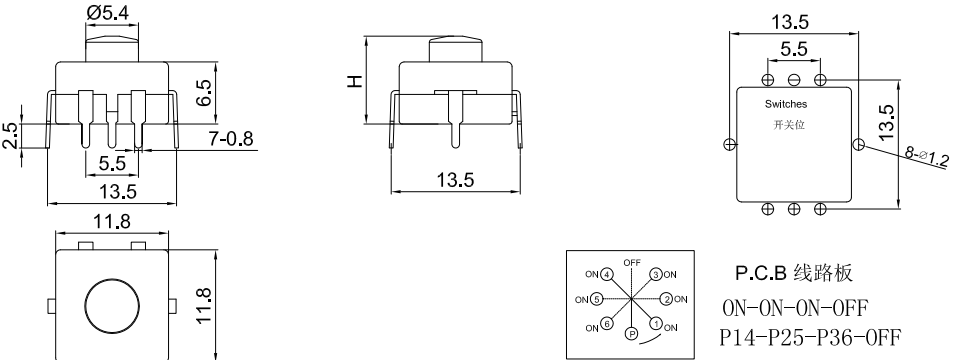

P.C.B 线路板  
ON-ON-ON-OFF  
P14-P25-P36-OFF

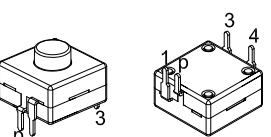

**PBS-07-214-P134**

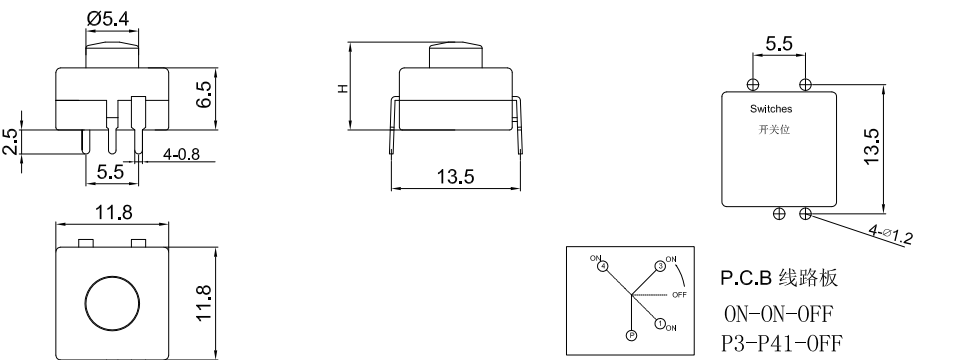

P.C.B 线路板  
ON-ON-OFF  
P3-P41-OFF

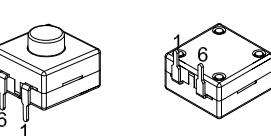

**PBS-07-112-16**

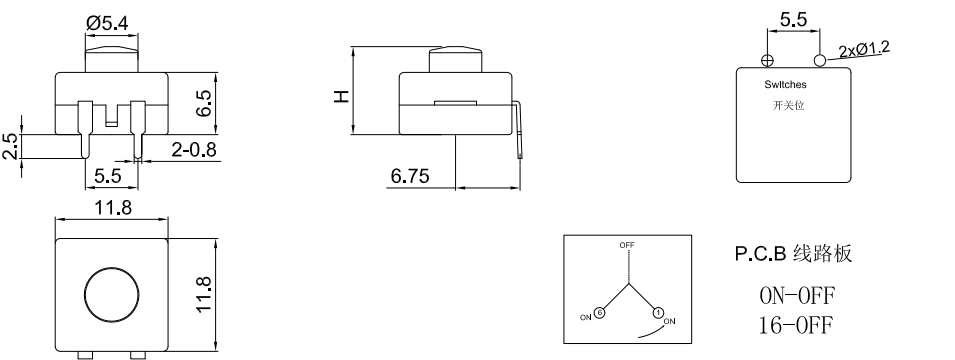

P.C.B 线路板  
ON-OFF  
16-OFF

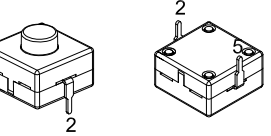

**PBS-07-112-25**

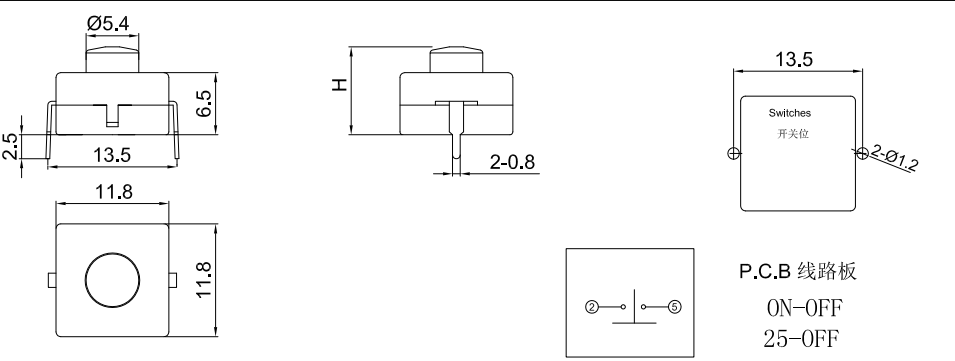

P.C.B 线路板  
ON-OFF  
25-OFF

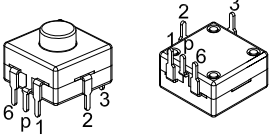

**PBS-07-315-P1236**

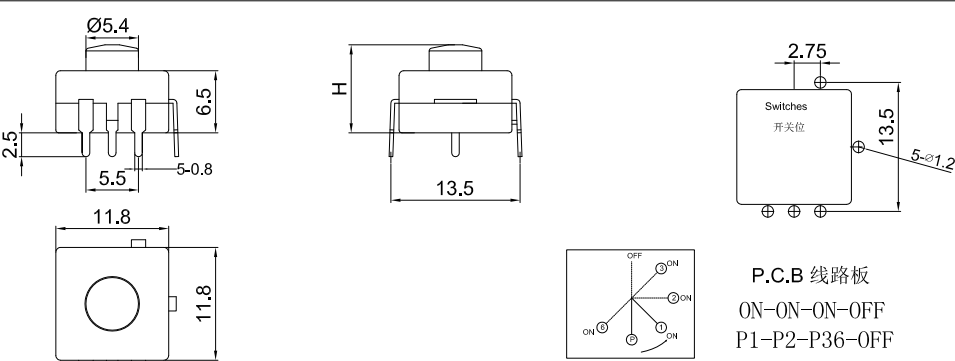

P.C.B 线路板  
ON-ON-ON-OFF  
P1-P2-P36-OFF

注：尚有较多脚位规格型号未一一列出，标准不带安装定位柱，定位柱，功能,克力，高度客户可根据自己的需要向我公司订货

高度 序号	H 高度 mm
A	9.4±0.1(推荐)
B	9.0±0.1
C	10.1±0.1
D	11.5±0.1

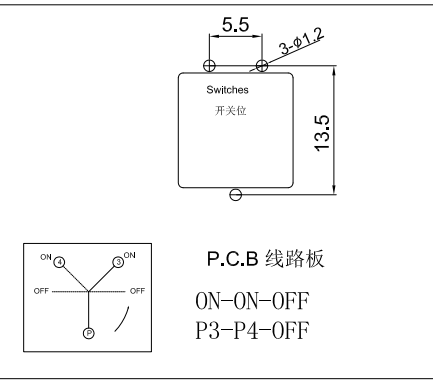
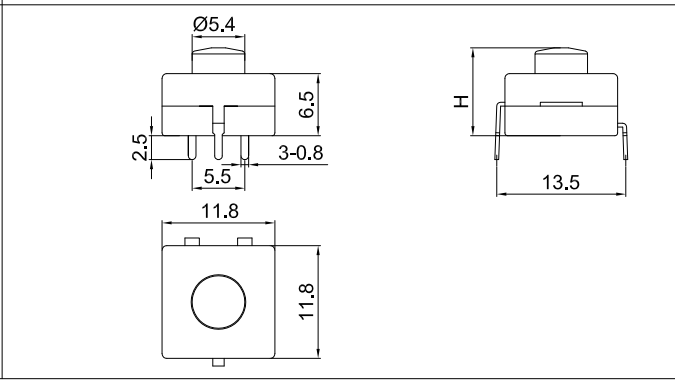
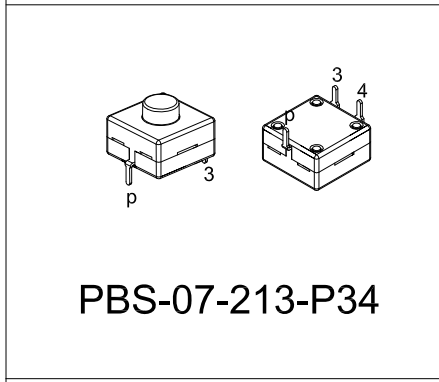
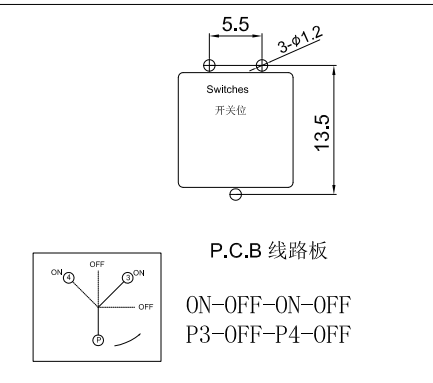
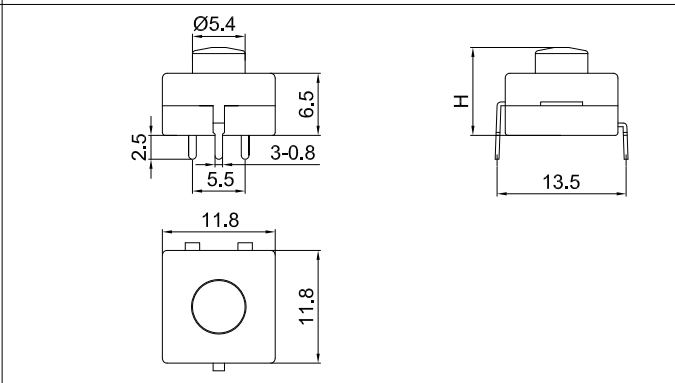
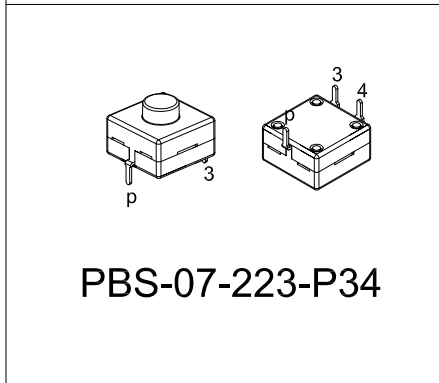
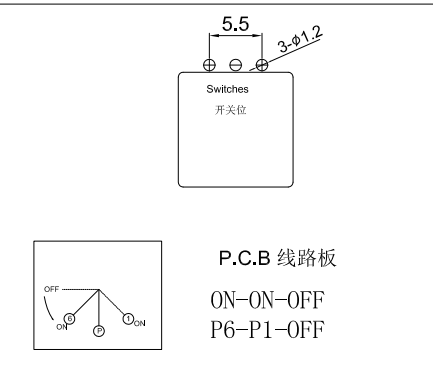
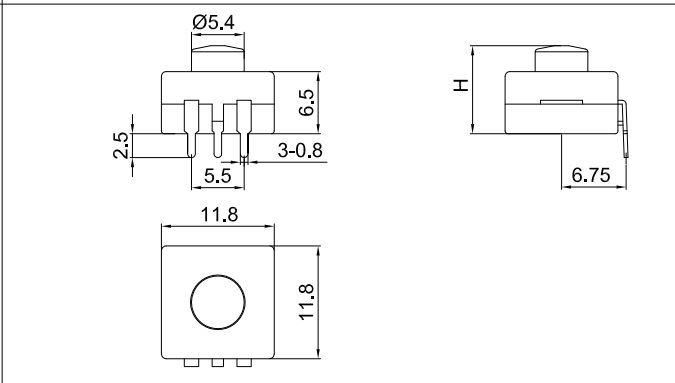
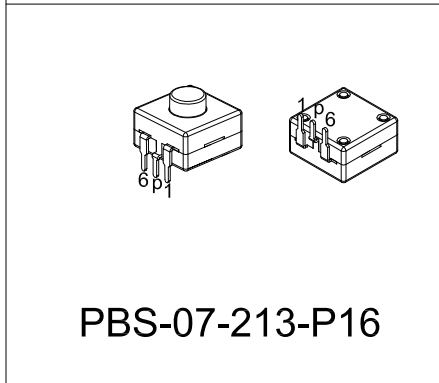
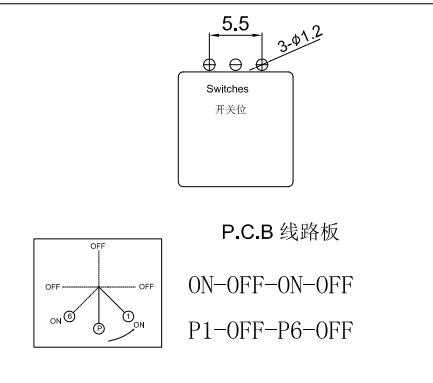
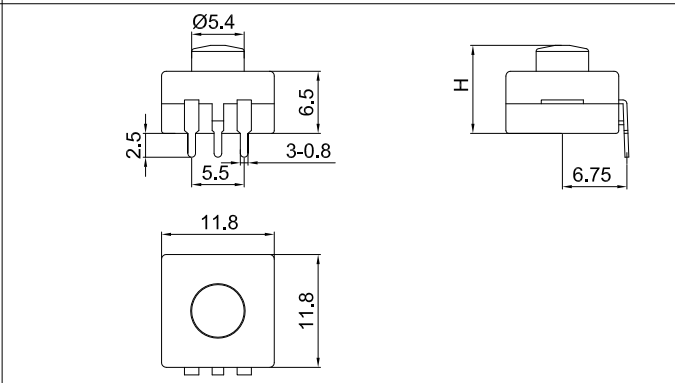
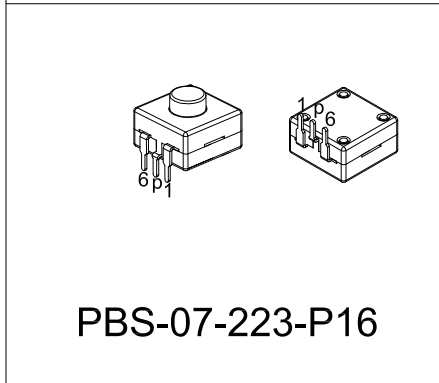
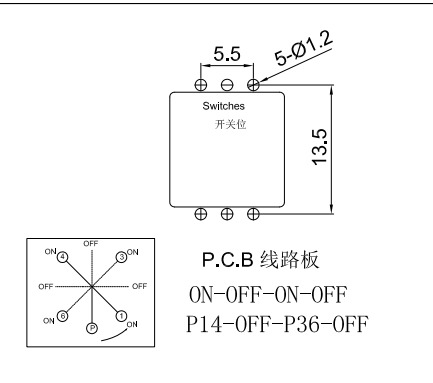
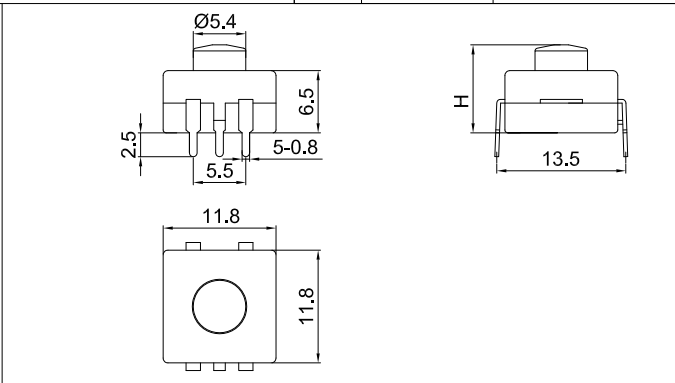
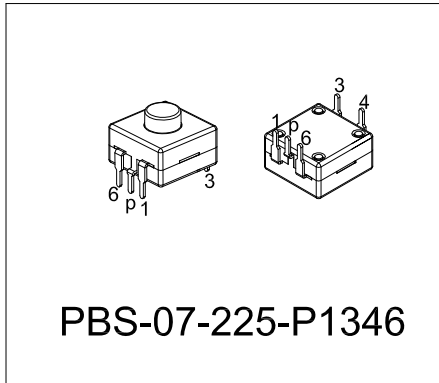

注：尚有较多脚位规格型号未一一列出，标准不带安装定位柱，定位柱，功能,克力，高度客户可根据自己的需要向我公司订货

高度 序号	H 高度 mm
A	9.4±0.1(推荐)
B	9.0±0.1
C	10.1±0.1
D	11.5±0.1

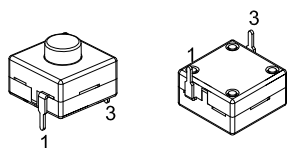

**PBS-07-112-13**

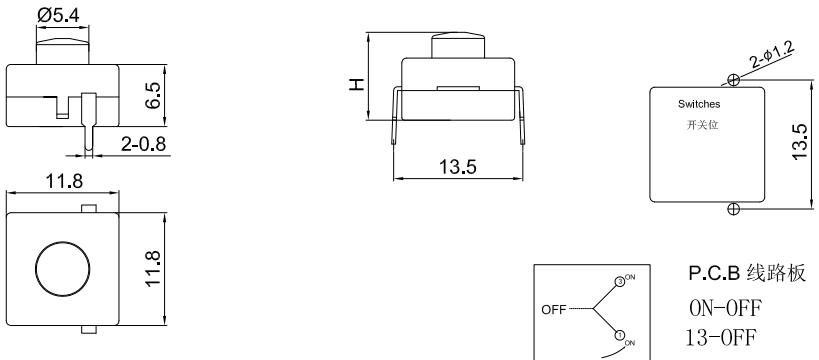

P.C.B 线路板  
ON-OFF  
13-OFF

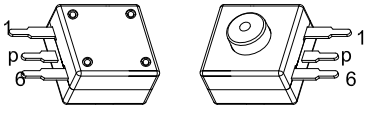

**PBS-07-213-P16**

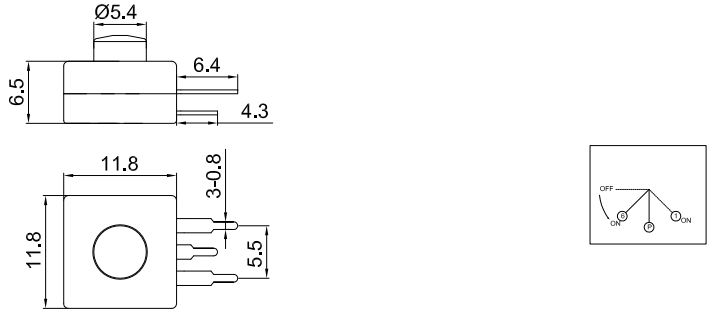

ON-ON-OFF  
P6-P1-OFF

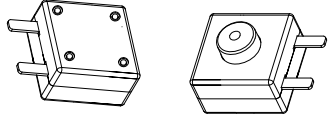

**PBS-07-112-i**

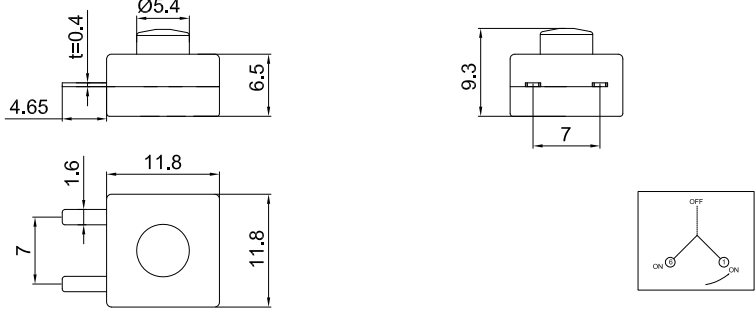

ON-OFF

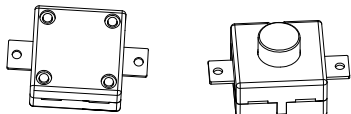

**PBS-07-112-W**

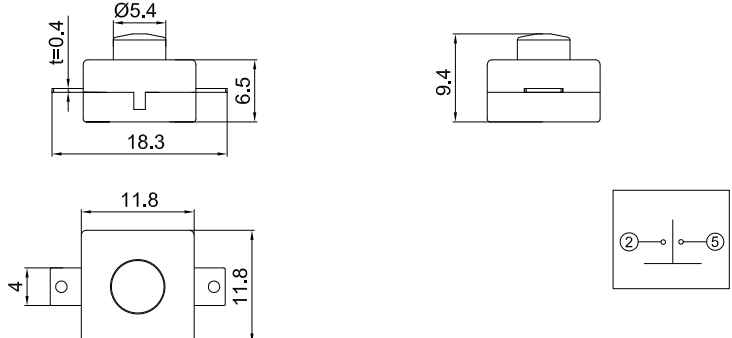

ON-OFF

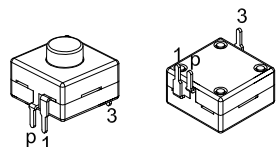

**PBS-07-213-P13**

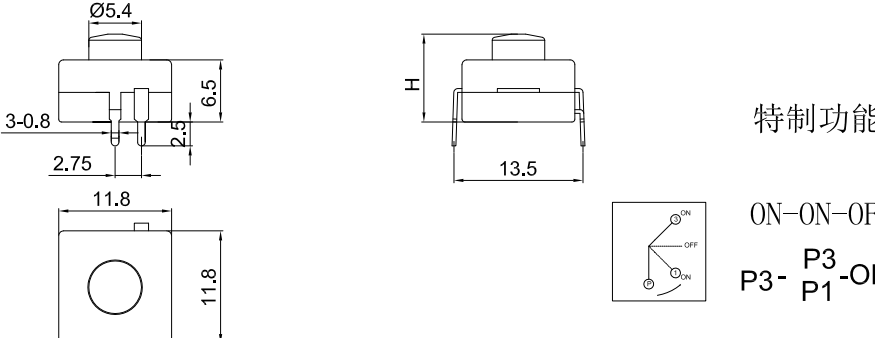

特制功能  
ON-ON-OFF  
P3- P3  
P1-OFF

注：尚有较多脚位规格型号未一一列出，标准不带安装定位柱，定位柱，功能,克力，高度客户可根据自己的需要向我公司订货

高度 序号	H 高度 mm
A	9.4±0.1(推荐)
B	9.0±0.1
C	10.1±0.1
D	11.5±0.1

克力范围 Operating Force	850±100g	绝缘电阻 Insulation Resistance	≥ 100MΩ
额定电流、电压 Rating	DC 30V 0.5A	抗电强度 Dielectric Intensity	≥ 1500VAC/min
接触电阻 Contact Resistance	≤ 100mΩ	电器寿命 Electrical Life	≥ 20000 Cycles

**PBS-06-317-P7**

P.C.B 线路板  
ON-ON-ON-OFF  
P14-P25-P36-OFF

**PBS-06-112-25**

P.C.B 线路板  
ON-OFF  
25-OFF

**PBS-06-213-P16**

P.C.B 线路板  
ON-ON-OFF  
P6-P1-OFF

**PBS-06-213-P34**

P.C.B 线路板  
ON-ON-OFF  
P3-P4-OFF

注：尚有较多脚位规格型号未一一列出，标准不带安装定位柱。定位柱、功能、克力、高度客户可根据自己的需要向我公司订货

# Daier Electron

## 12X12mm Size B Series

高度 序号	H 高度 mm
A	9.4±0.1(推荐)
B	9.0±0.1
C	10.1±0.1
D	11.5±0.1

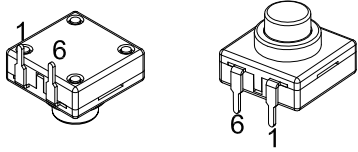
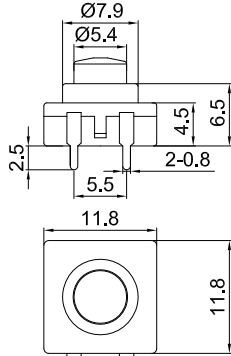
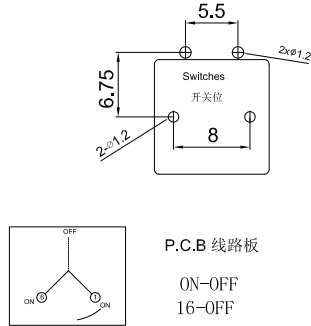
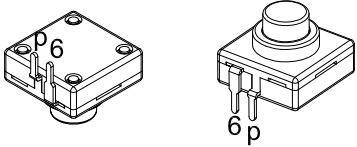
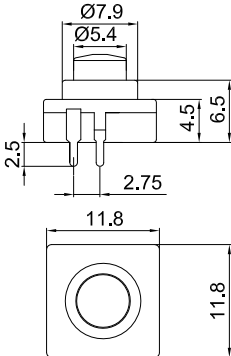
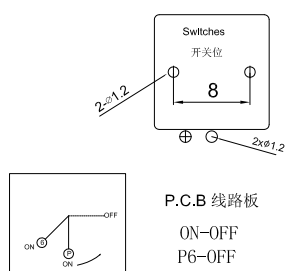
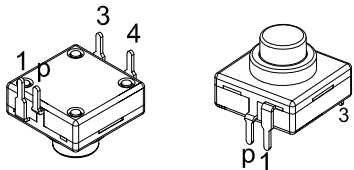
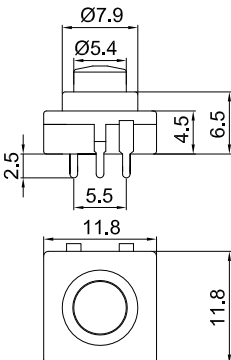
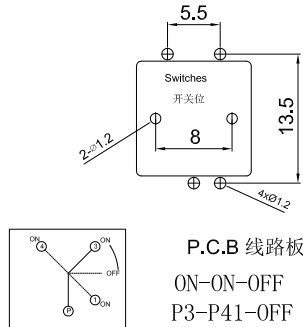
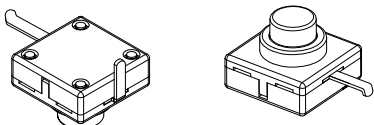
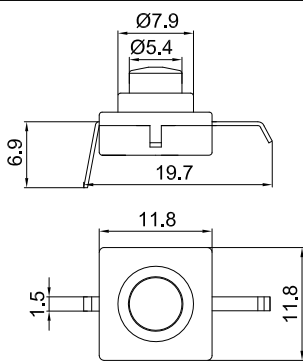
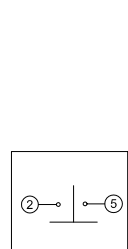
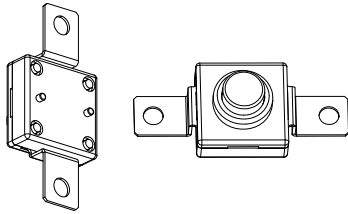
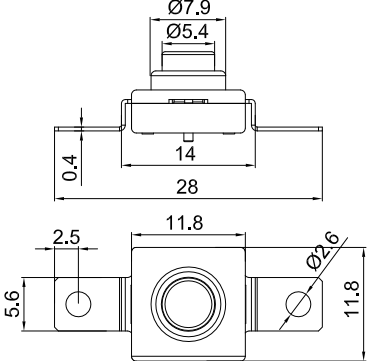
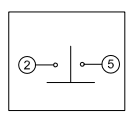
 <p><b>PBS-06-112-16</b></p>		 <p>P.C.B 线路板 ON-OFF 16-OFF</p>
 <p><b>PBS-06-112-P6</b></p>		 <p>P.C.B 线路板 ON-OFF P6-OFF</p>
 <p><b>PBS-06-214-P134</b></p>		 <p>P.C.B 线路板 ON-ON-OFF P3-P41-OFF</p>
 <p><b>PBS-06-112-LS</b></p>		 <p>特制脚 ON-OFF</p>
 <p><b>PBS-06-112-Z</b></p>		 <p>特制脚 ON-OFF</p>

注：尚有较多脚位规格型号未一一列出，标准不带安装定位柱，定位柱，功能，克力，高度客户可根据自己的需要向我公司订货

克力范围 Operating Force	850±100g	绝缘电阻 Insulation Resistance	≥ 100MΩ
额定电流、电压 Rating	DC 30V 0.5A	抗电强度 Dielectric Intensity	≥1500VAC/min
接触电阻 Contact Resistance	≤ 100mΩ	电器寿命 Electrical Life	≥20000 Cycles

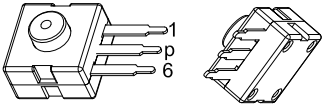

**PBS-05-213-P16**

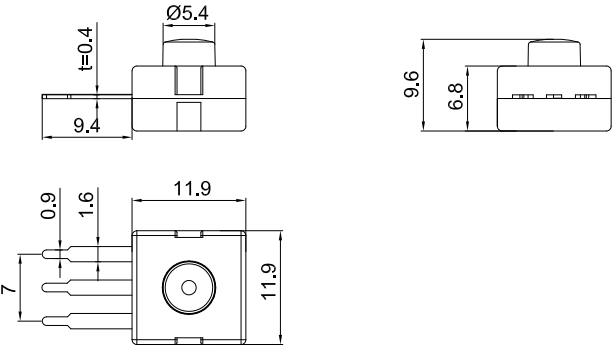
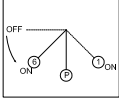
ON-ON-OFF  
P6-P1-OFF

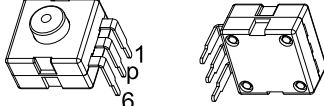

**PBS-05A-213-P16**

Switches 开关位

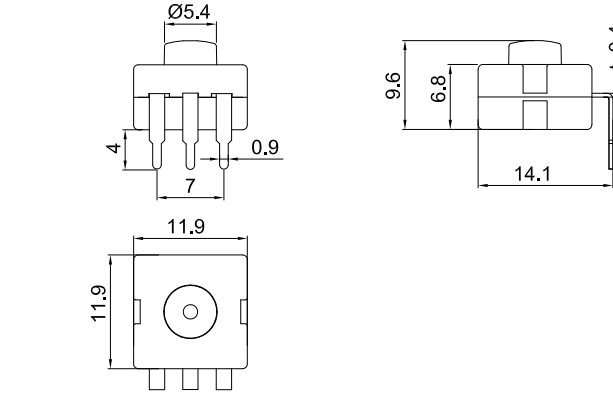
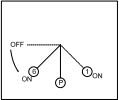

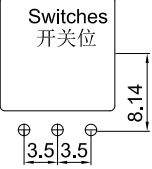
P.C.B 线路板  
ON-ON-OFF  
P6-P1-OFF

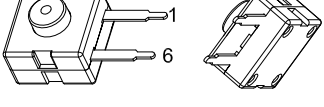

**PBS-05-112-16**

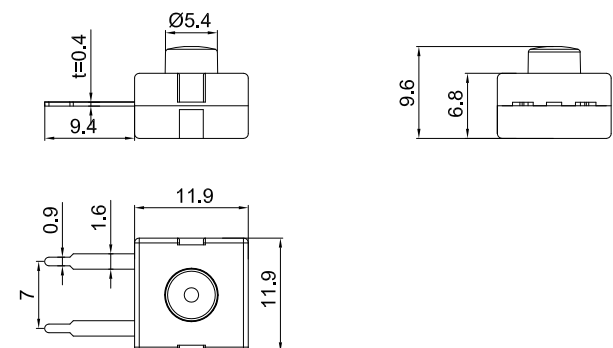
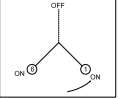
ON-OFF  
16-OFF

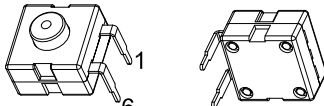

**PBS-05A-112-16**

Switches 开关位

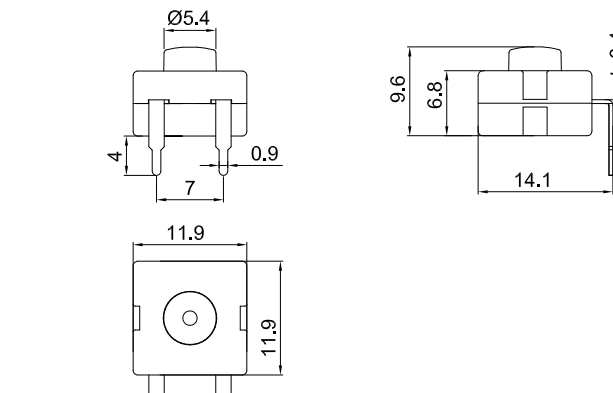
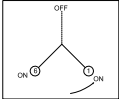

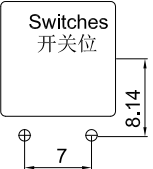
P.C.B 线路板  
ON-OFF  
16-OFF

注：尚有较多脚位规格型号未一一列出，功能、克力、高度客户可根据自己的需要向我公司订货

克力范围 Operating Force	700±100g	绝缘电阻 Insulation Resistance	≥ 100MΩ
额定电流、电压 Rating	AC 250V 1A	抗电强度 Dielectric Intensity	≥ 1500VAC/min
接触电阻 Contact Resistance	≤ 100mΩ	电器寿命 Electrical Life	≥ 20000 Cycles

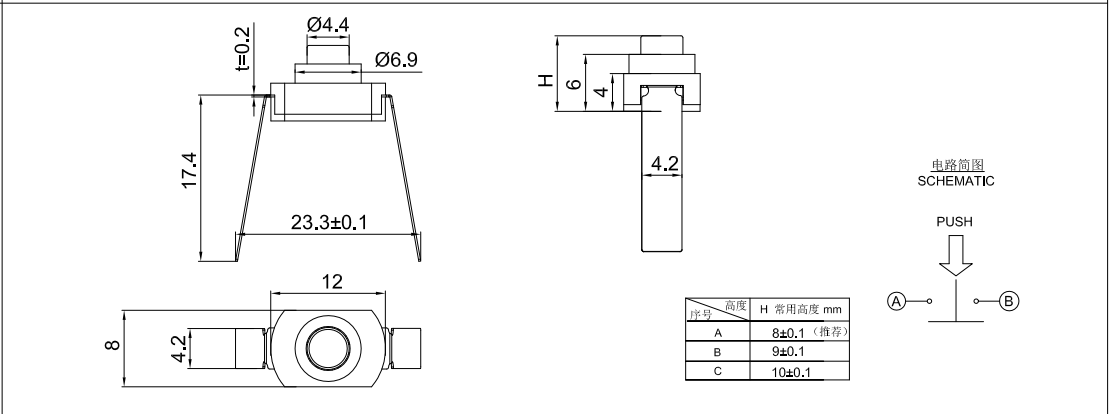
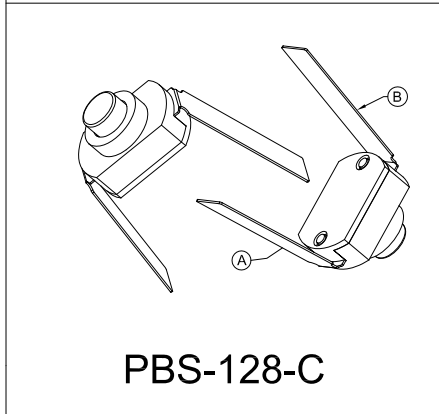
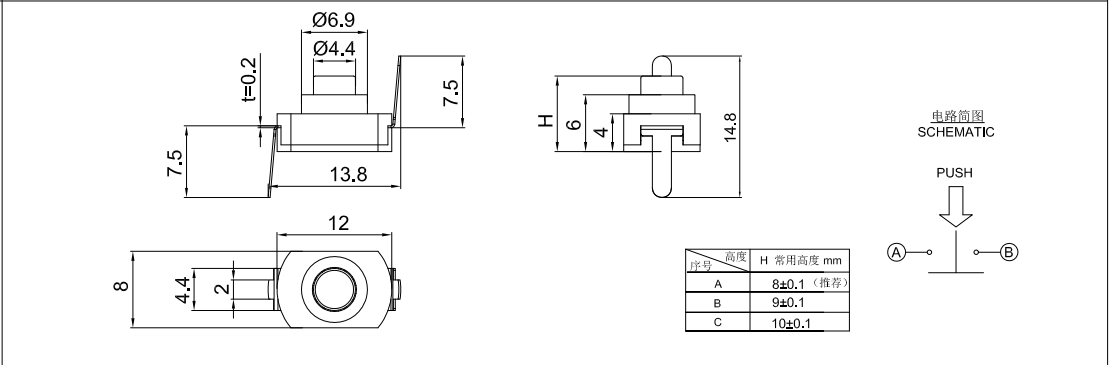
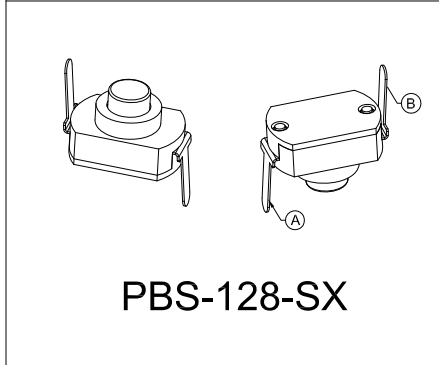
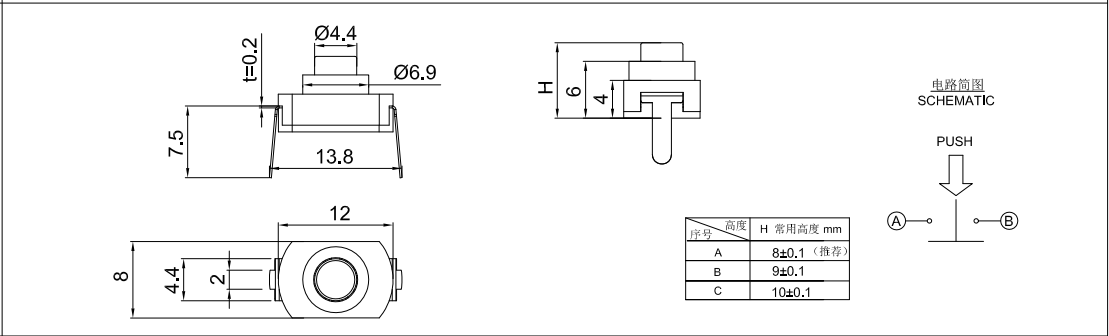
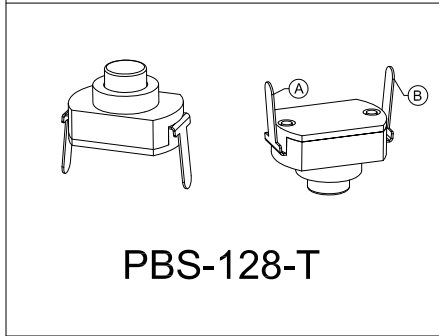
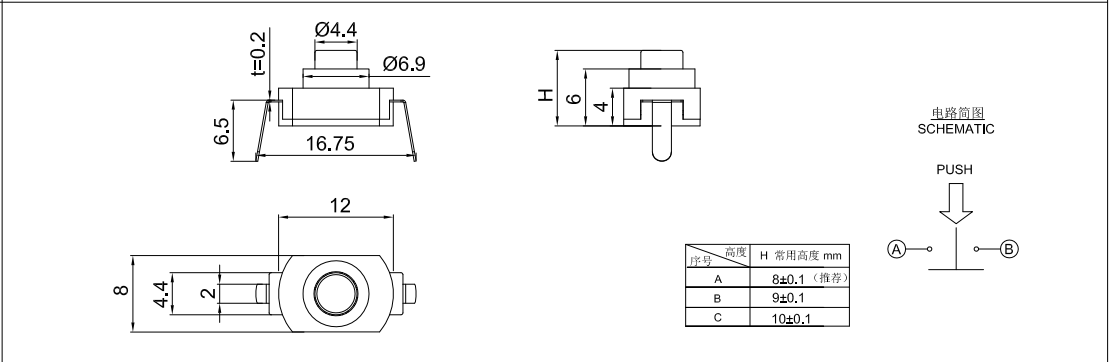
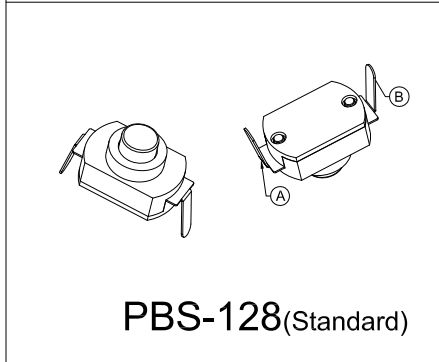
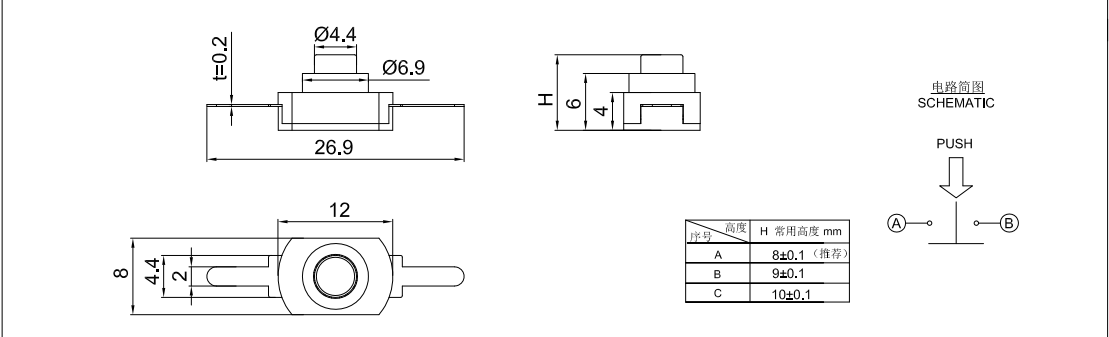
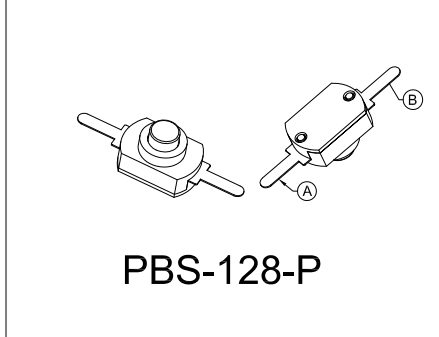

# Daier Electron

## 12X8mm Series

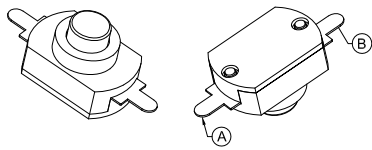

PBS-128-D

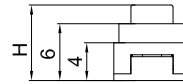
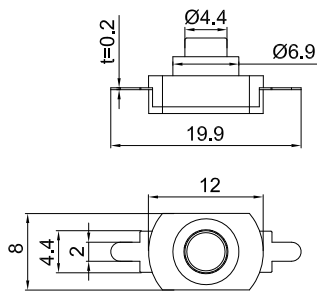

序号	高度	H 常用高度 mm
A		8±0.1 (推荐)
B		9±0.1
C		10±0.1

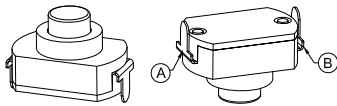
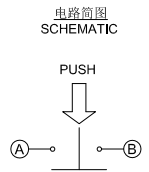

PBS-128-W

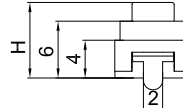
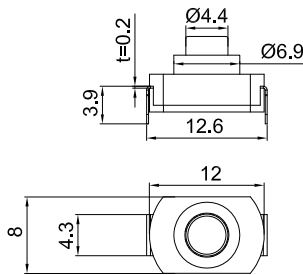

序号	高度	H 常用高度 mm
A		8±0.1 (推荐)
B		9±0.1
C		10±0.1

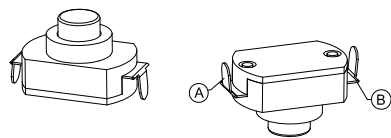
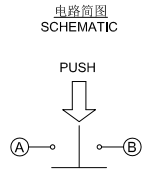

PBS-128-DA

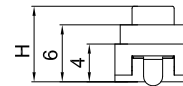
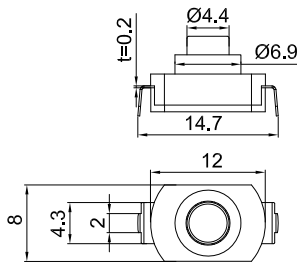

序号	高度	H 常用高度 mm
A		8±0.1 (推荐)
B		9±0.1
C		10±0.1

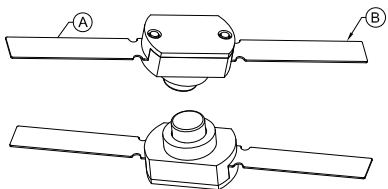
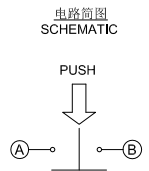

PBS-128-CP

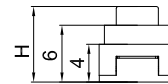
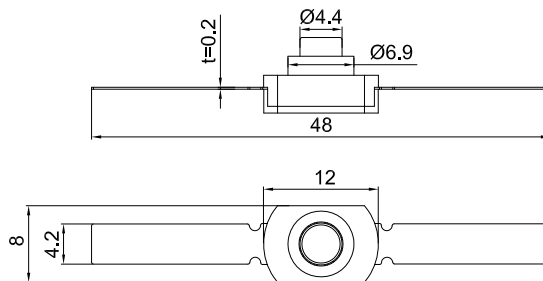

序号	高度	H 常用高度 mm
A		8±0.1 (推荐)
B		9±0.1
C		10±0.1

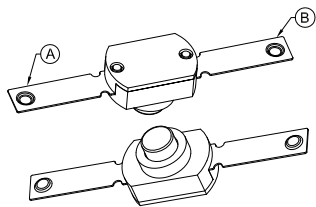
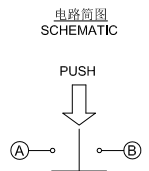

PBS-128-ZP

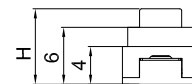
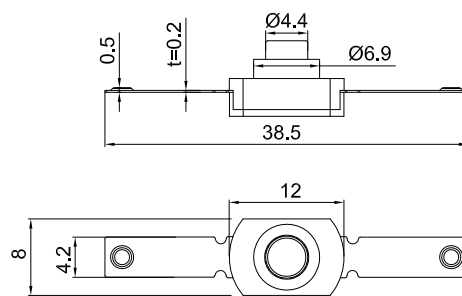

序号	高度	H 常用高度 mm
A		8±0.1 (推荐)
B		9±0.1
C		10±0.1

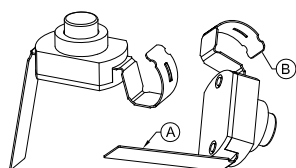
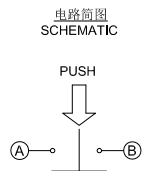

PBS-128-F

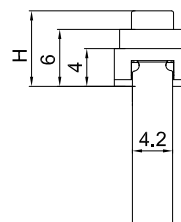
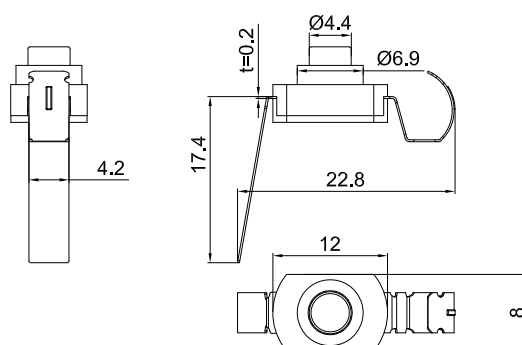

序号	高度	H 常用高度 mm
A		8±0.1 (推荐)
B		9±0.1
C		10±0.1

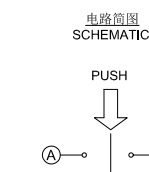



克力范围 Operating Force	650±100g	绝缘电阻 Insulation Resistance	≥ 100MΩ
额定电流、电压 Rating	DC 30V 0.5A	抗电强度 Dielectric Intensity	≥1500VAC/min
接触电阻 Contact Resistance	≤ 100mΩ	电器寿命 Electrical Life	≥20000 Cycles

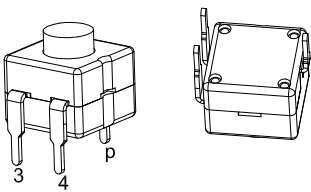

**PBS88-213-P34W**

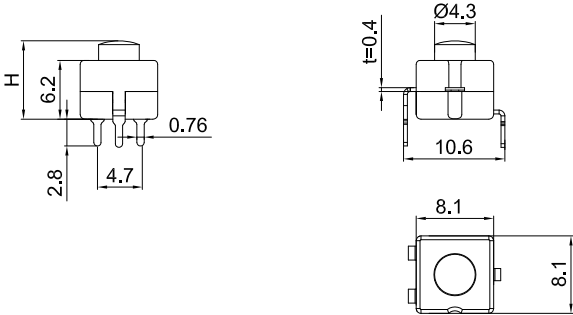

ON-ON-OFF  
P4-P3-OFF

序号	高度 H 高度 mm
A	8.2±0.1
B	10.3±0.1

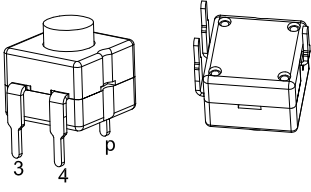

**PBS88-203-P34W**

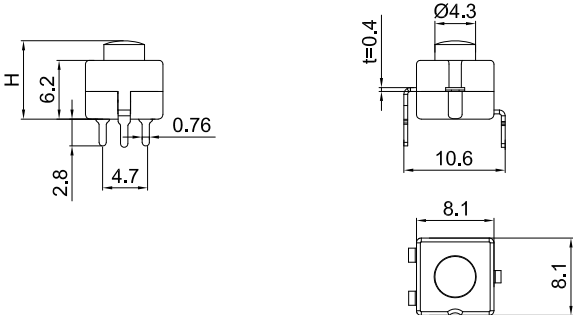

ON-ON  
P4-P3

序号	高度 H 高度 mm
A	8.2±0.1
B	10.3±0.1

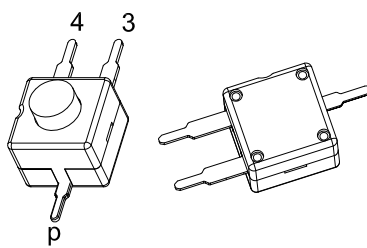

**PBS88-213-P34Z**

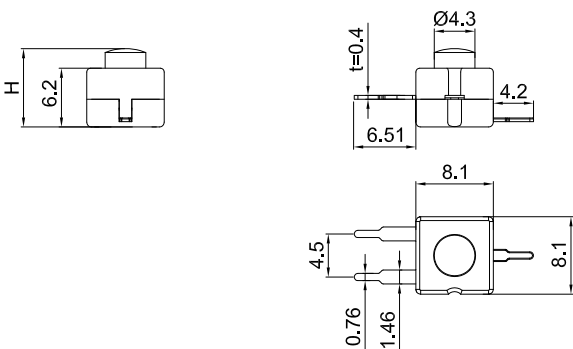

ON-ON-OFF  
P4-P3-OFF

序号	高度 H 高度 mm
A	8.2±0.1
B	10.3±0.1

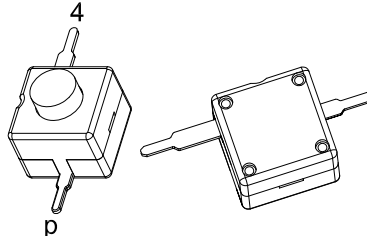

**PBS88-112-P4Z**

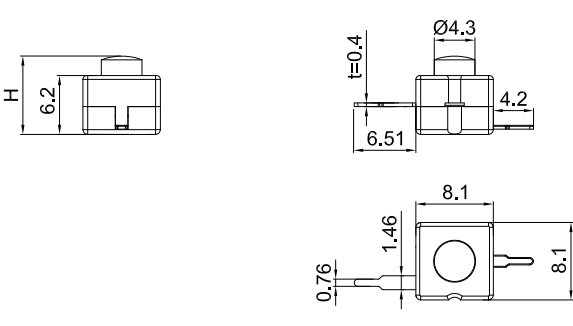

ON-OFF  
P4-OFF

序号	高度 H 高度 mm
A	8.2±0.1
B	10.3±0.1

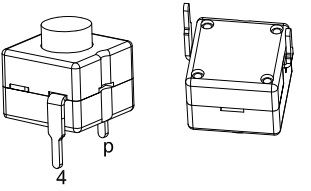

**PBS88-112-P4W**

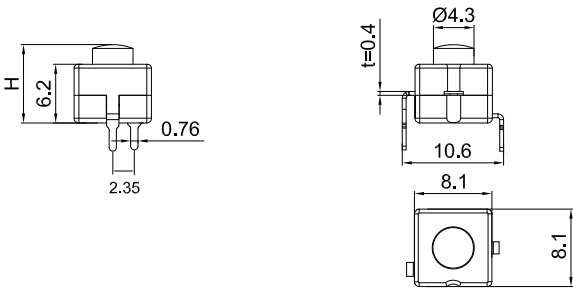

ON-OFF  
P4-OFF

序号	高度 H 高度 mm
A	8.2±0.1
B	10.3±0.1

# Daier Electron

## 12X12mm DT Series

克力范围 Operating Force	700±100g	绝缘电阻 Insulation Resistance	≥ 100MΩ
额定电流、电压 Rating	DC 30V 2A	抗电强度 Dielectric Intensity	≥ 1500VAC/min
接触电阻 Contact Resistance	≤ 100mΩ	电器寿命 Electrical Life	≥ 20000 Cycles

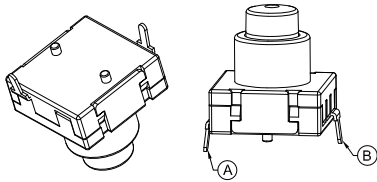

PBS12DT-X

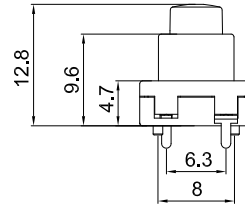
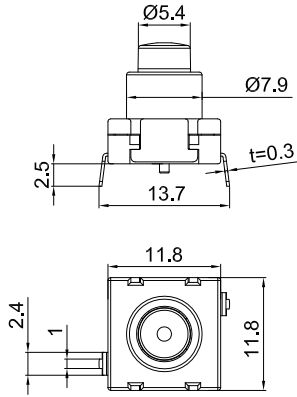

电路简图 SCHEMATIC

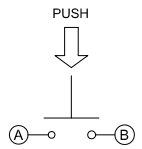

点通说明: 带锁开关 轻按下来, 点触点通, 锁住长通, 再接一次断开。

定位柱, 客户根据自己需要自行选择

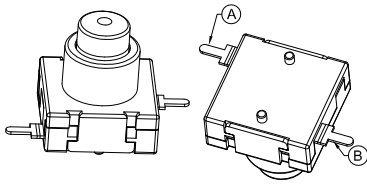

PBS12DT-P

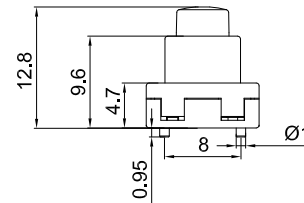
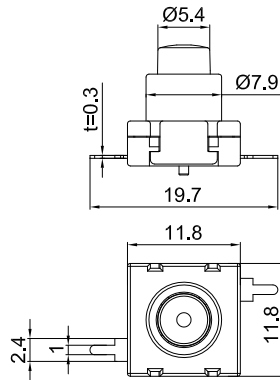

电路简图 SCHEMATIC

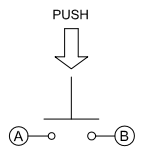

点通说明: 带锁开关 轻按下来, 点触点通, 锁住长通, 再接一次断开。

定位柱, 客户根据自己需要自行选择

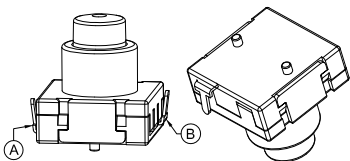

PBS12DT-S

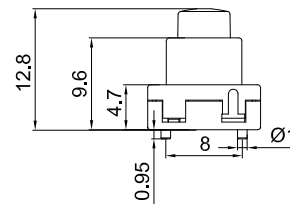
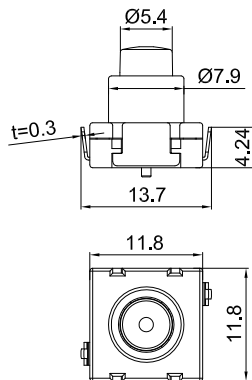

电路简图 SCHEMATIC

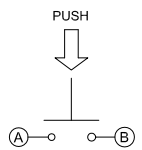

点通说明: 带锁开关 轻按下来, 点触点通, 锁住长通, 再接一次断开。

定位柱, 客户根据自己需要自行选择

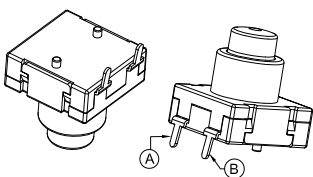

PBS12DT - M

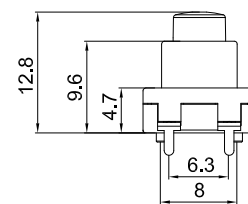
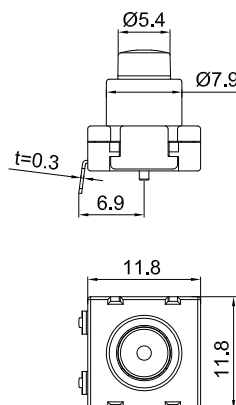

电路简图 SCHEMATIC

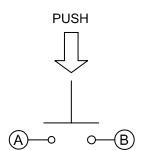

点通说明: 带锁开关 轻按下来, 点触点通, 锁住长通, 再接一次断开。

定位柱, 客户根据自己需要自行选择

克力范围 Operating Force	700±100g	绝缘电阻 Insulation Resistance	≥ 100MΩ
额定电流、电压 Rating	DC 30V 0.5A	抗电强度 Dielectric Intensity	≥1500VAC/min
接触电阻 Contact Resistance	≤ 100mΩ	电器寿命 Electrical Life	≥20000 Cycles

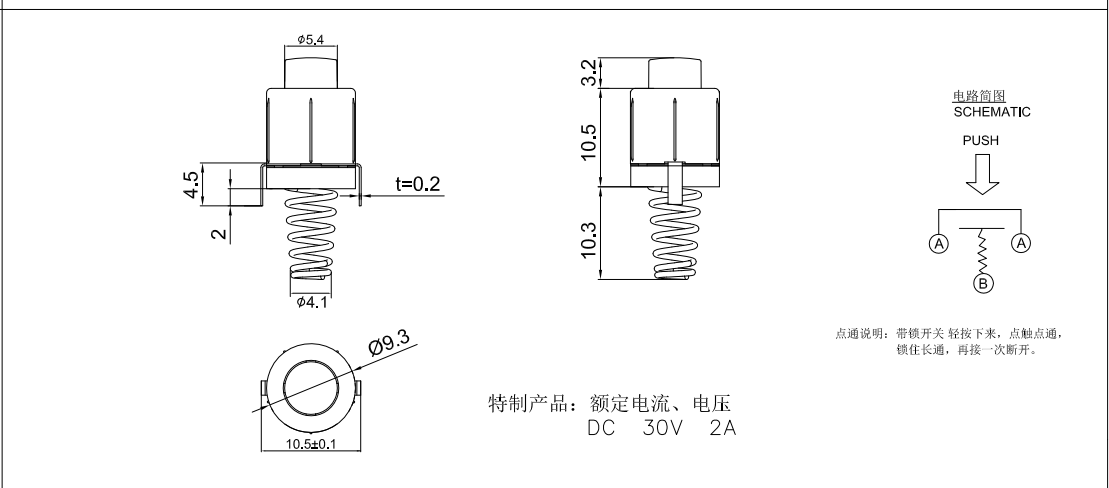
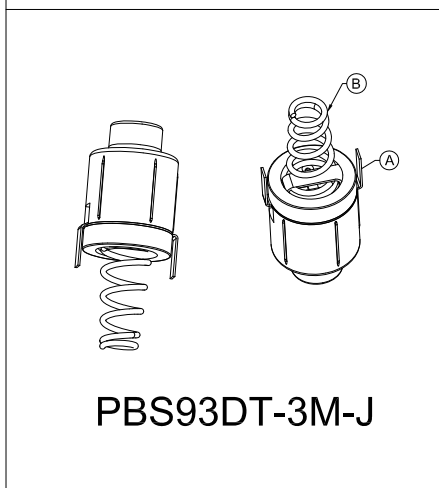
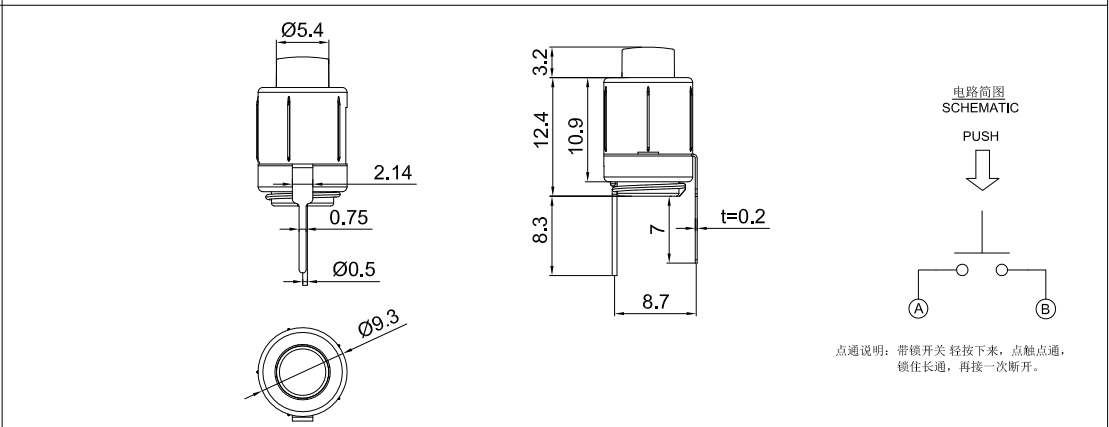
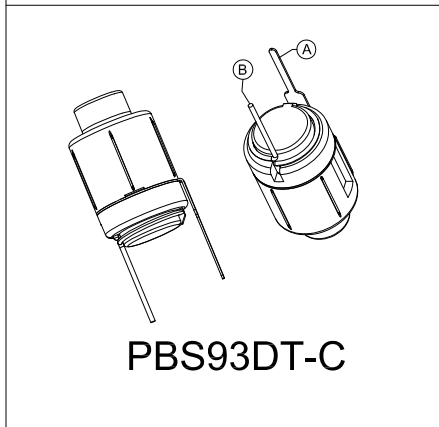
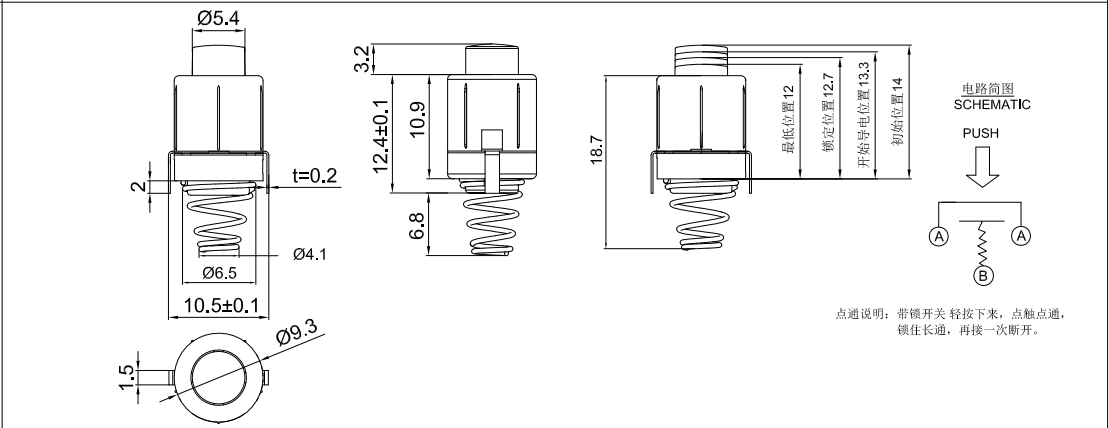
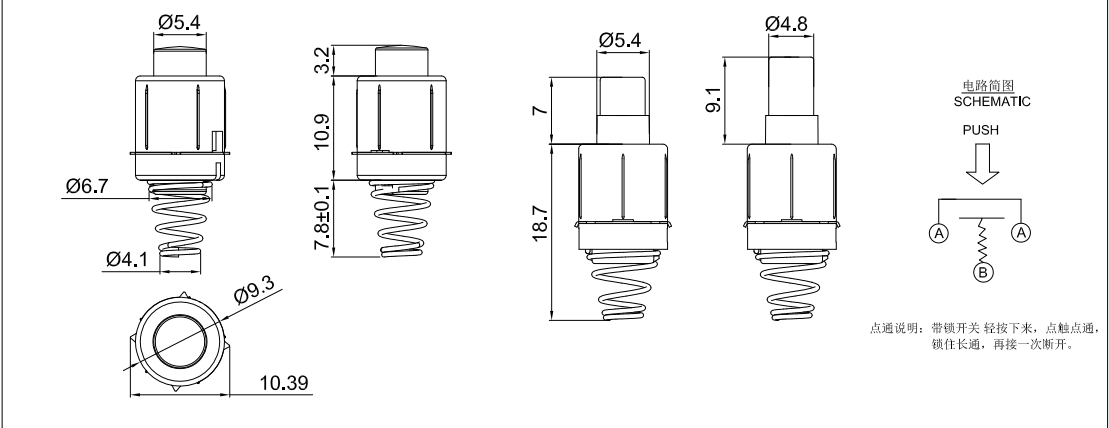
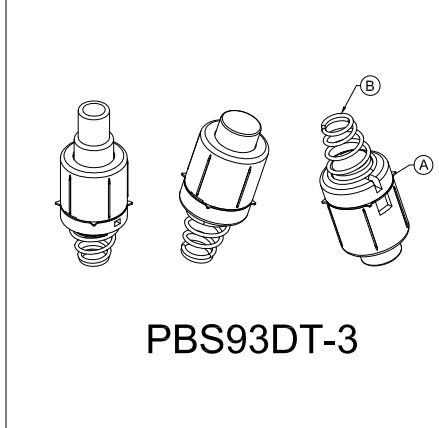

克力范围 Operating Force	700±100g	绝缘电阻 Insulation Resistance	≥ 100MΩ
额定电流、电压 Rating	DC 30V 0.5A	抗电强度 Dielectric Intensity	≥ 1500VAC/min
接触电阻 Contact Resistance	≤ 100mΩ	电器寿命 Electrical Life	≥ 20000 Cycles

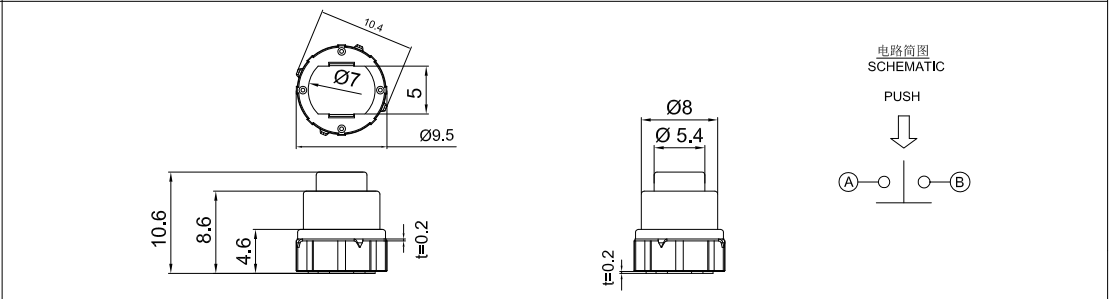
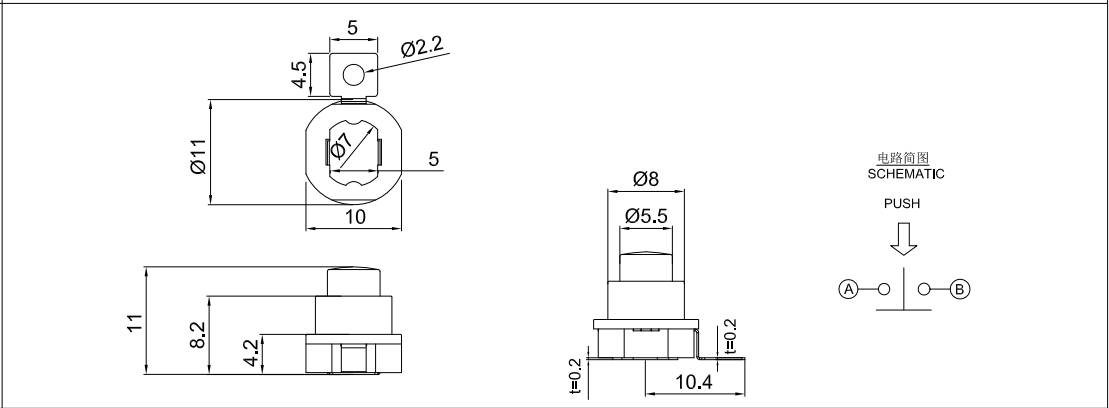
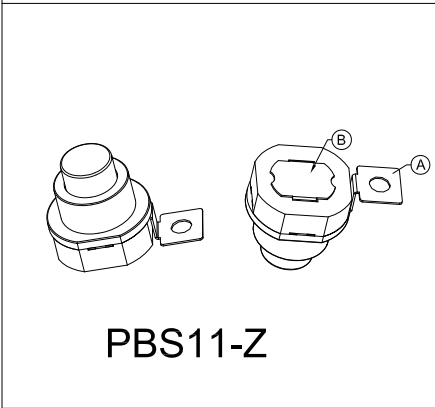
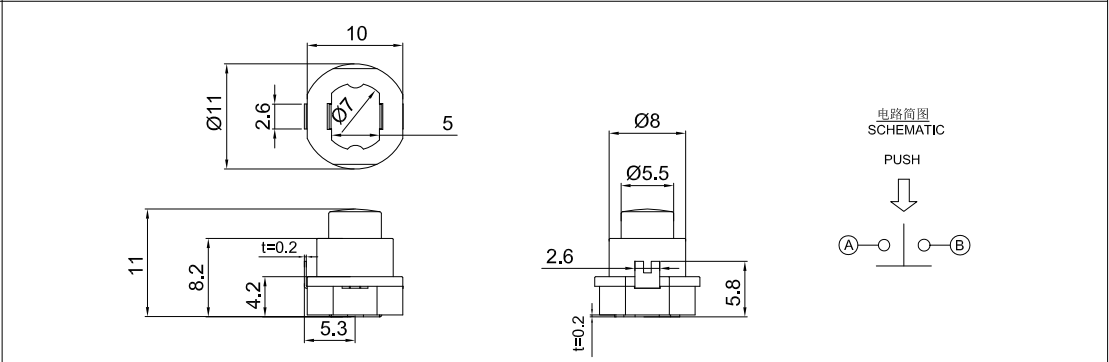
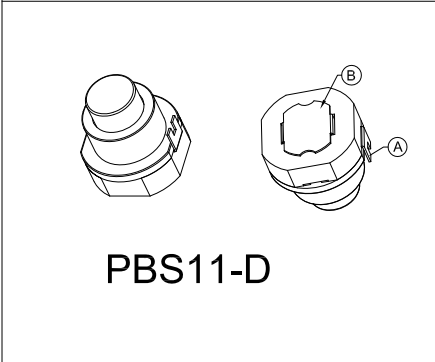
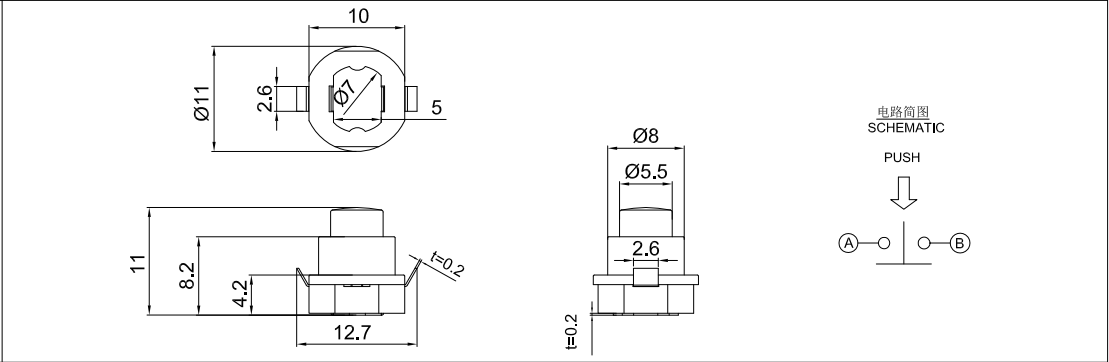
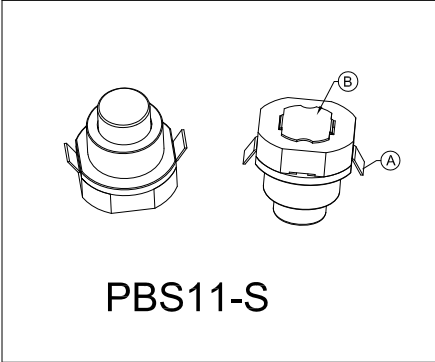
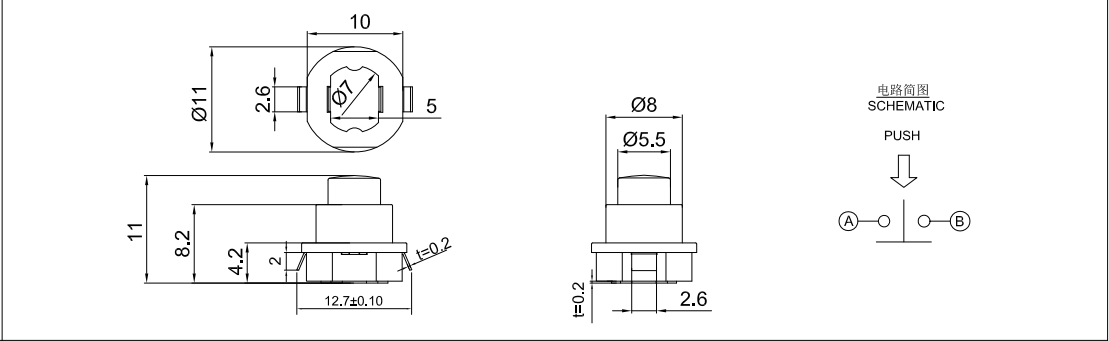
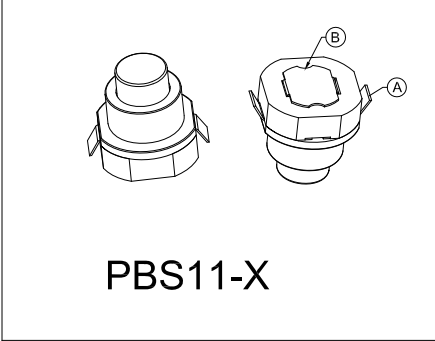

克力范围 Operating Force	700±100g	绝缘电阻 Insulation Resistance	≥ 100MΩ
额定电流、电压 Rating	AC 250V 1.5A	抗电强度 Dielectric Intensity	≥1500VAC/min
接触电阻 Contact Resistance	≤ 100mΩ	电器寿命 Electrical Life	≥20000 Cycles

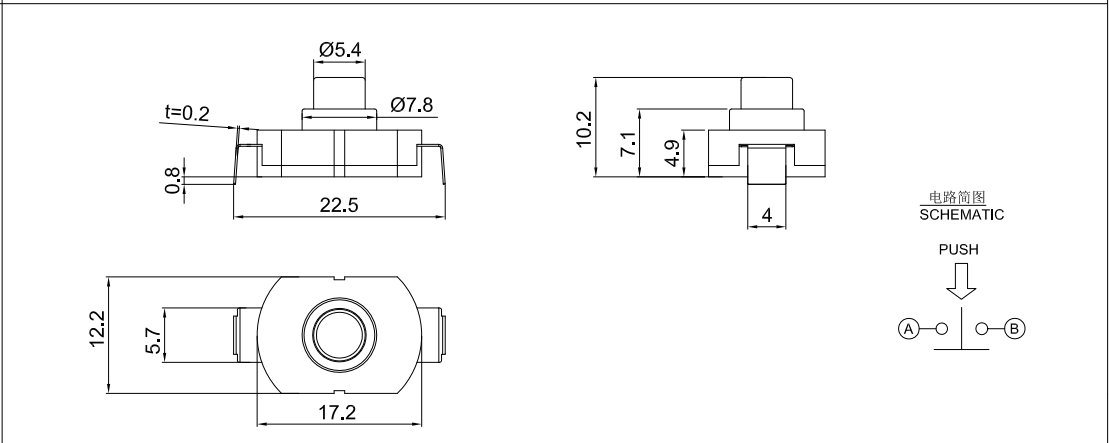
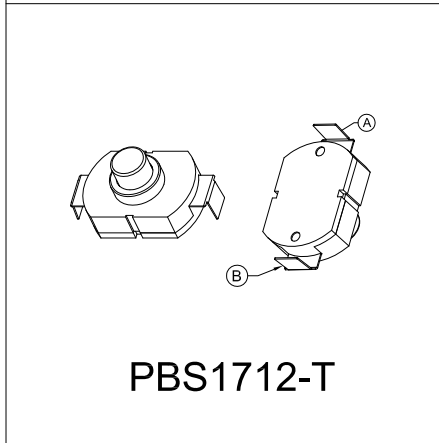
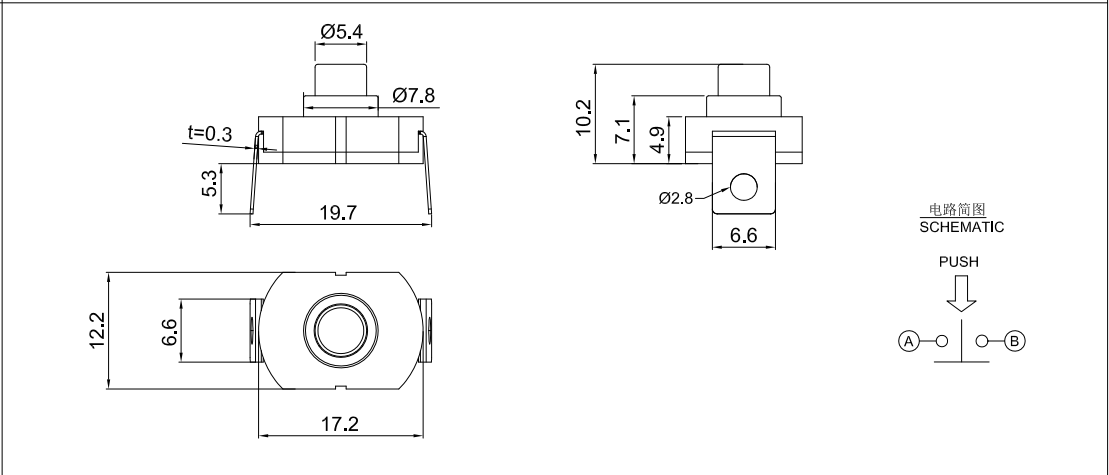
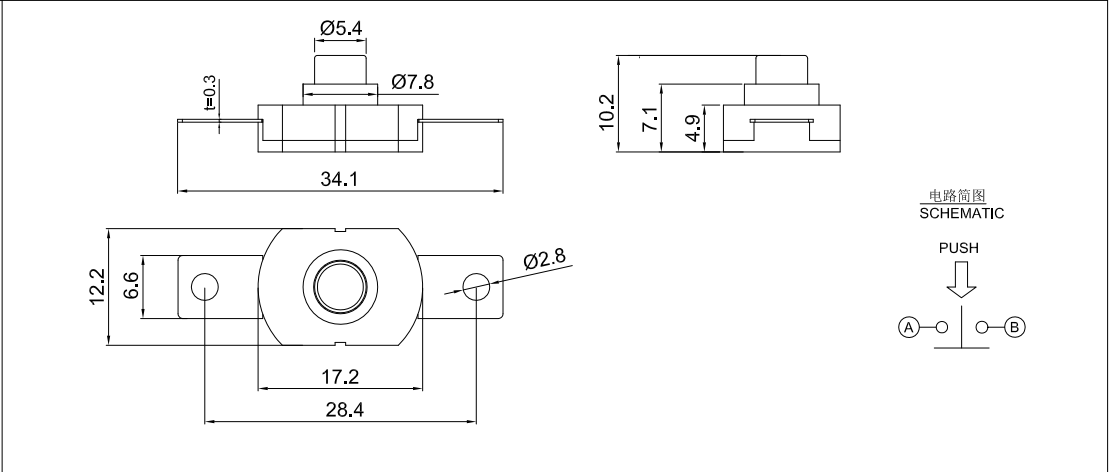
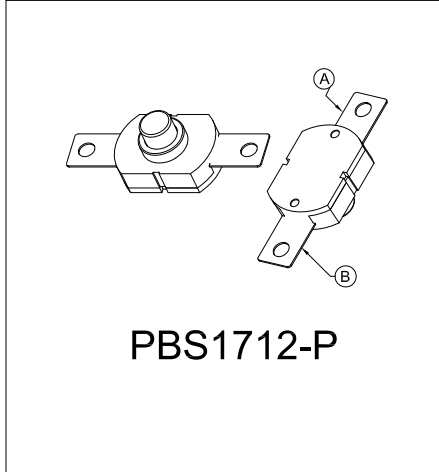
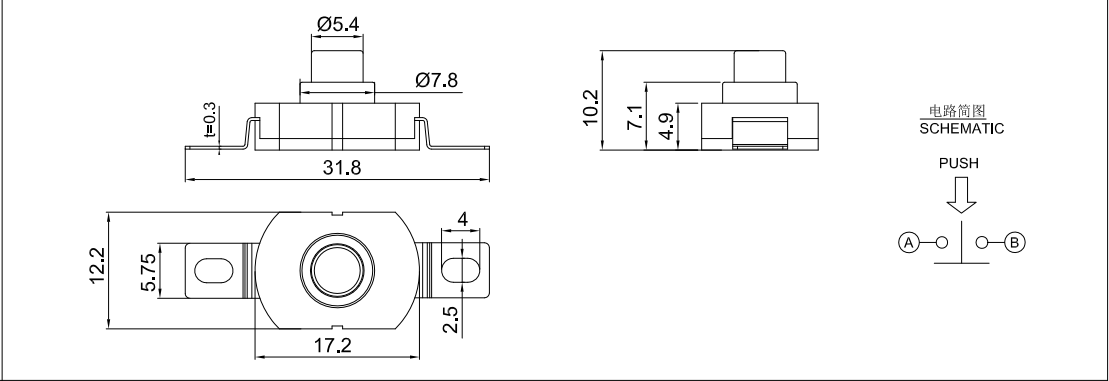
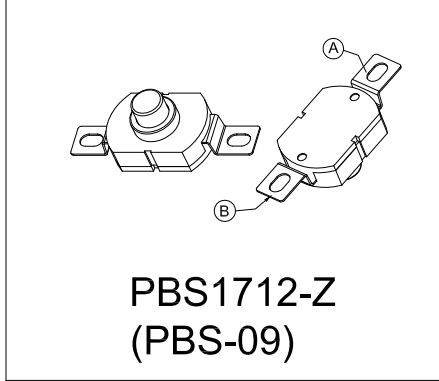

克力范围 Operating Force	700±100g	绝缘电阻 Insulation Resistance	≥ 100MΩ
额定电流、电压 Rating	AC 250V 1.5A	抗电强度 Dielectric Intensity	≥1500VAC/min
接触电阻 Contact Resistance	≤ 100mΩ	电器寿命 Electrical Life	≥20000 Cycles

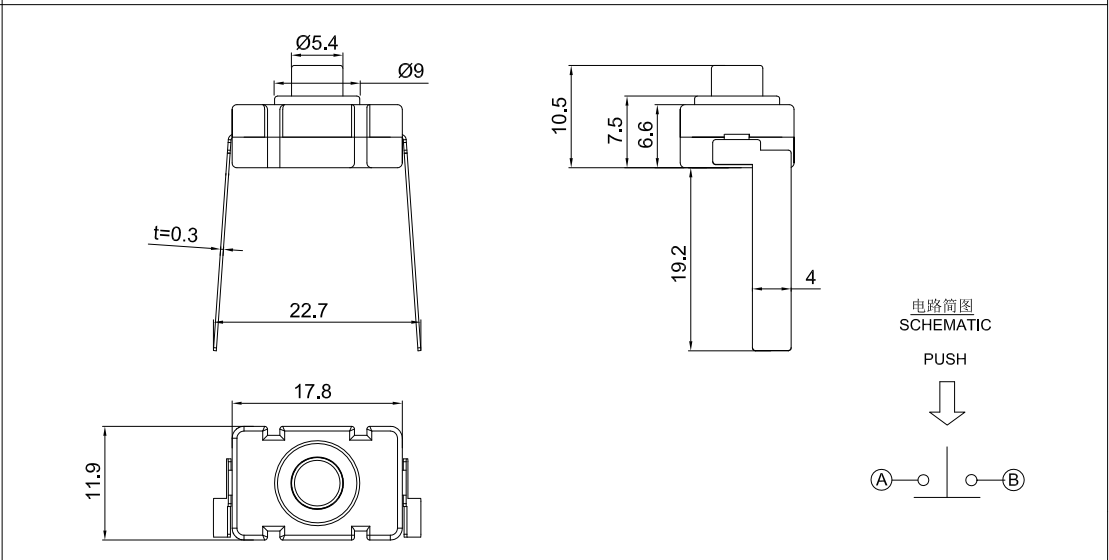
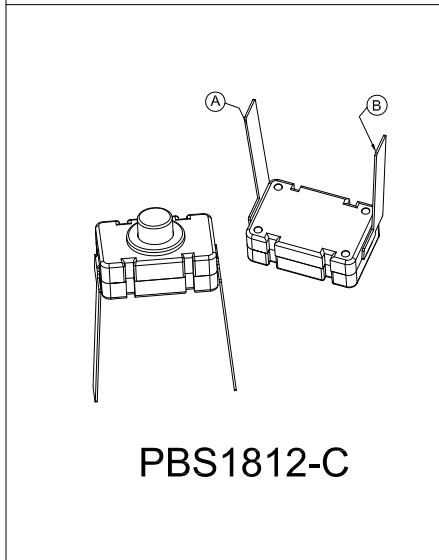
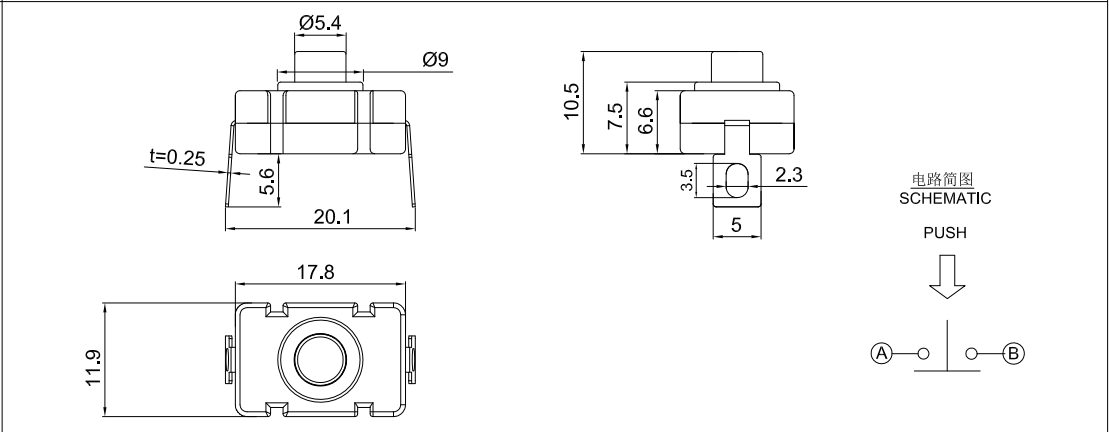
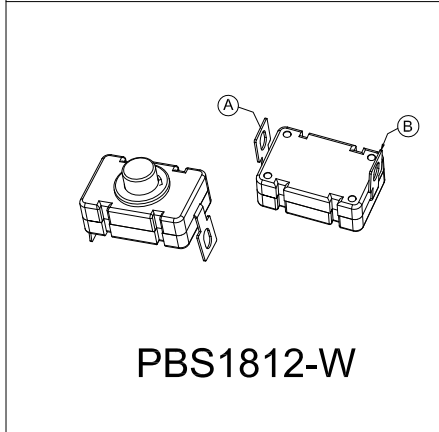
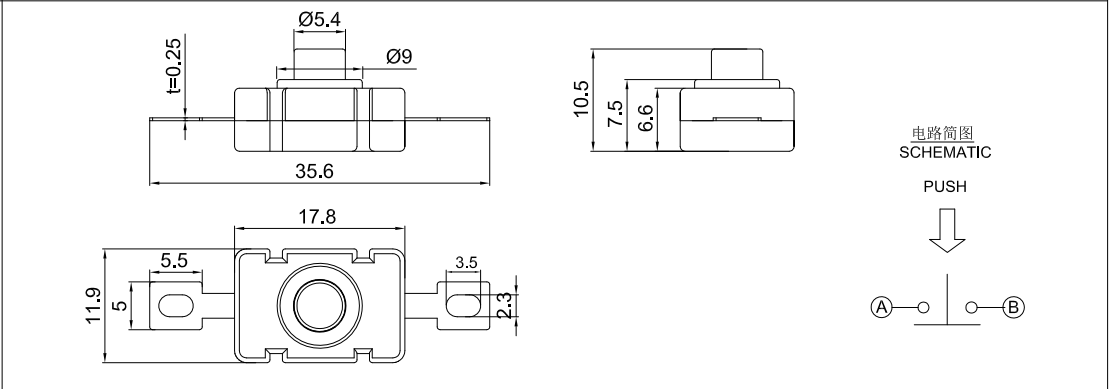
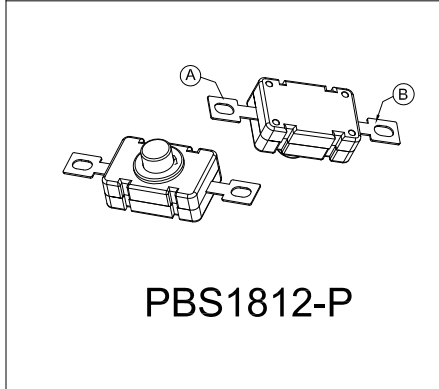
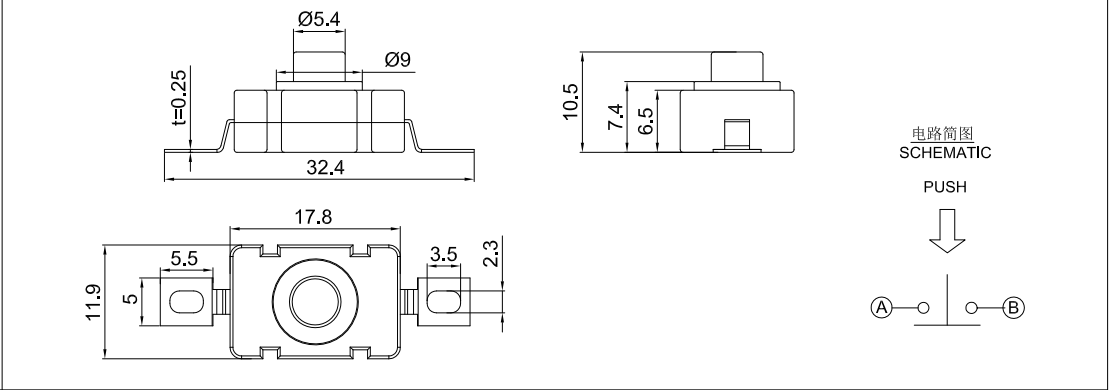
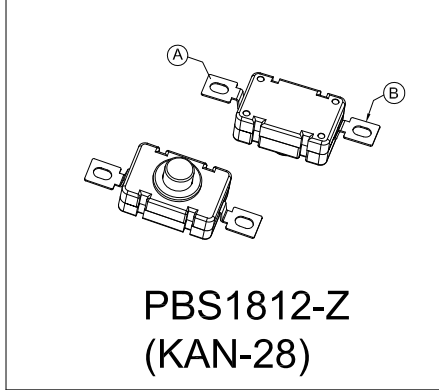

克力范围 Operating Force	700±100g	绝缘电阻 Insulation Resistance	≥ 100MΩ
额定电流、电压 Rating	AC 250V 1.5A	抗电强度 Dielectric Intensity	≥1500VAC/min
接触电阻 Contact Resistance	≤ 100mΩ	电器寿命 Electrical Life	≥20000 Cycles

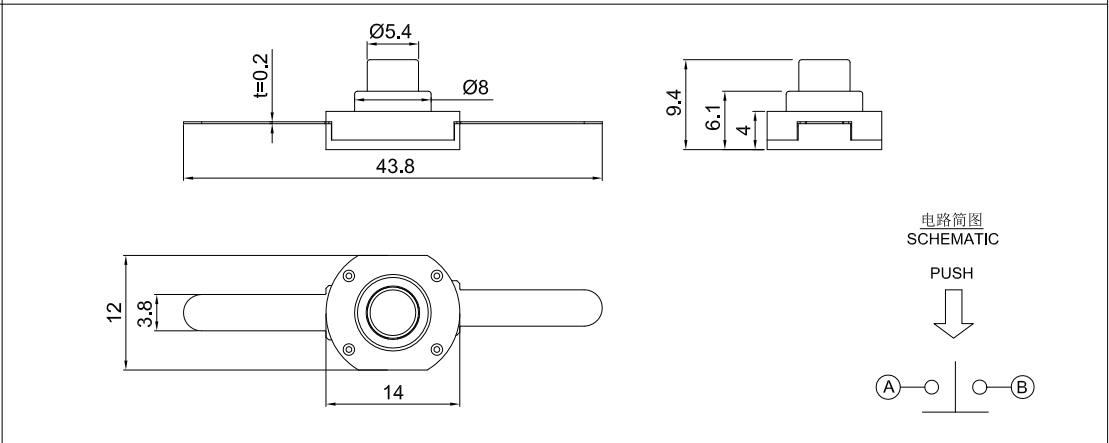
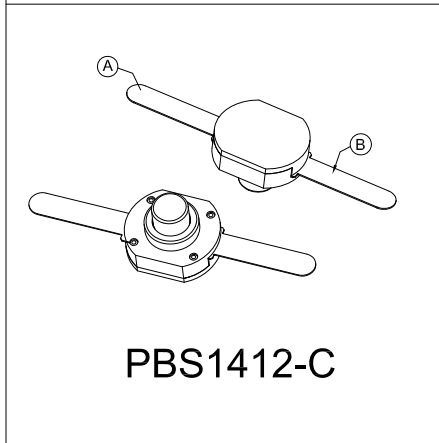
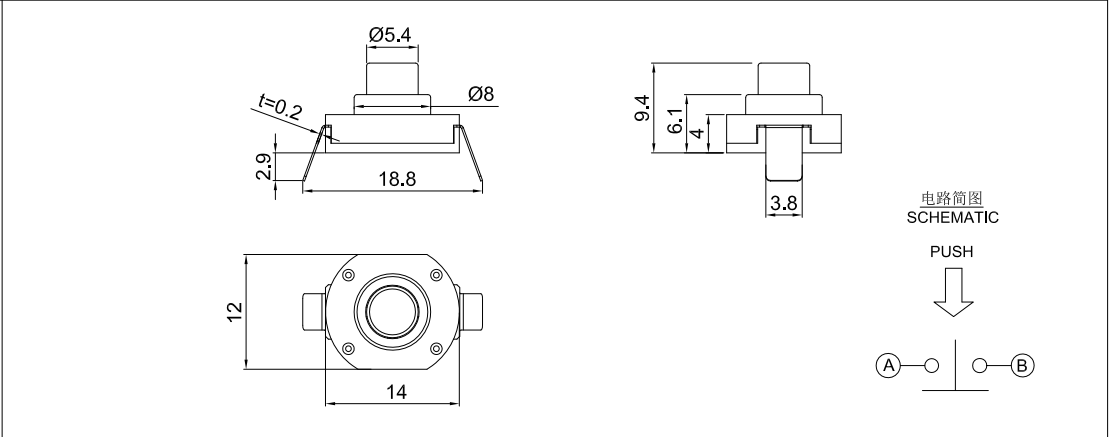
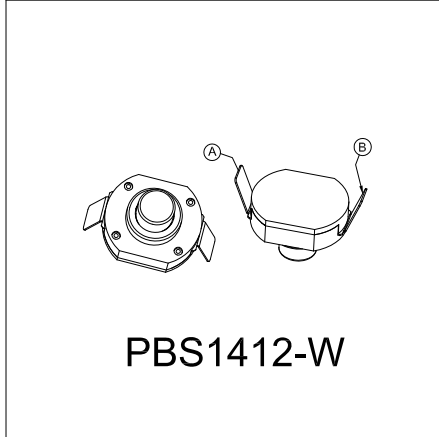
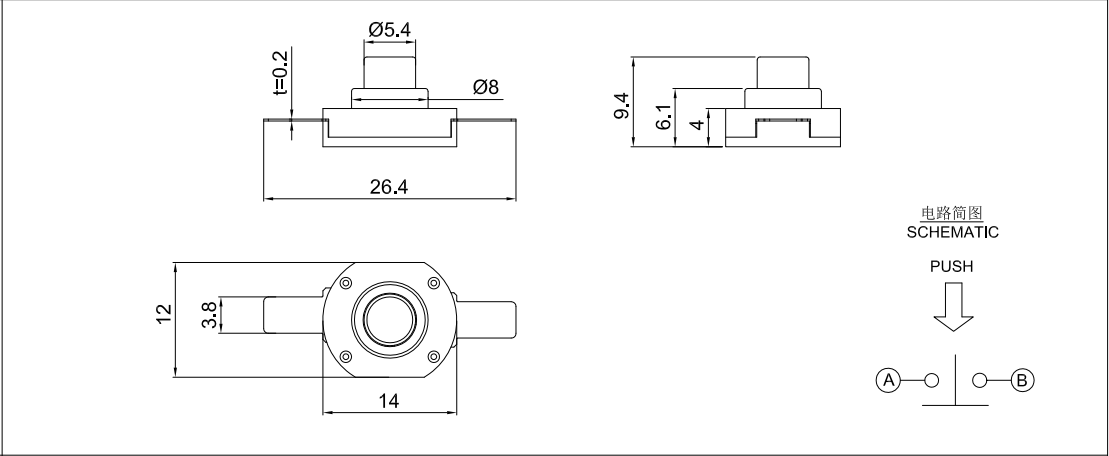
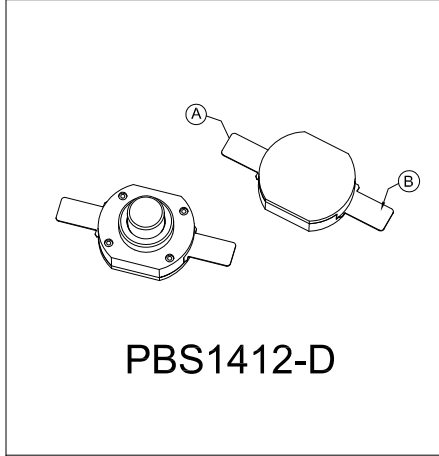
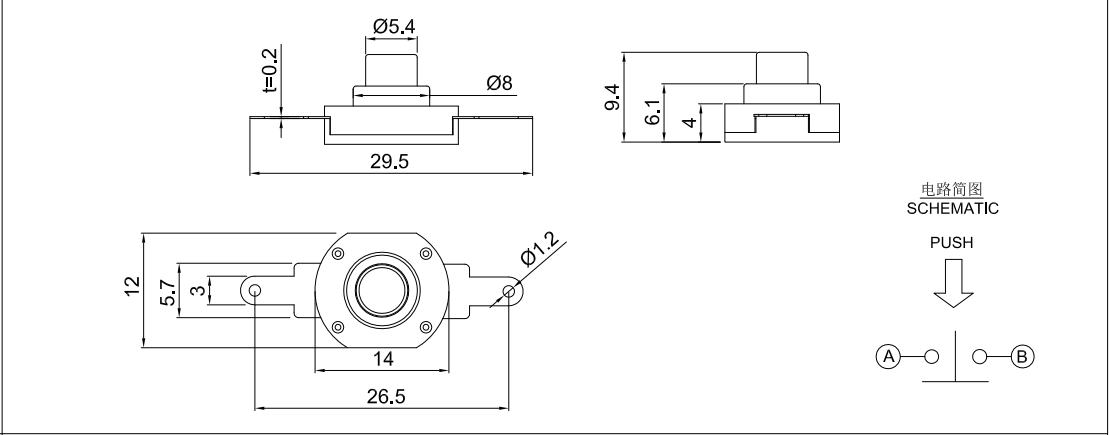
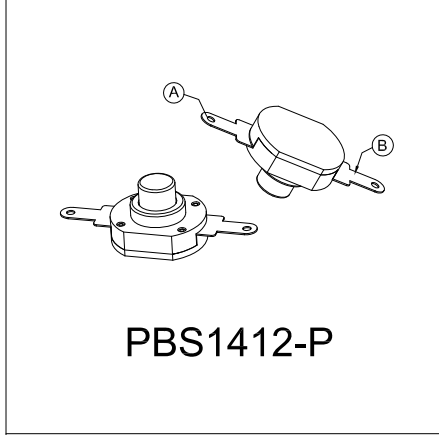

克力范围 Operating Force	700±100g	绝缘电阻 Insulation Resistance	≥ 100MΩ
额定电流、电压 Rating	AC 250V 1.5A	抗电强度 Dielectric Intensity	≥1500VAC/min
接触电阻 Contact Resistance	≤ 100mΩ	电器寿命 Electrical Life	≥20000 Cycles

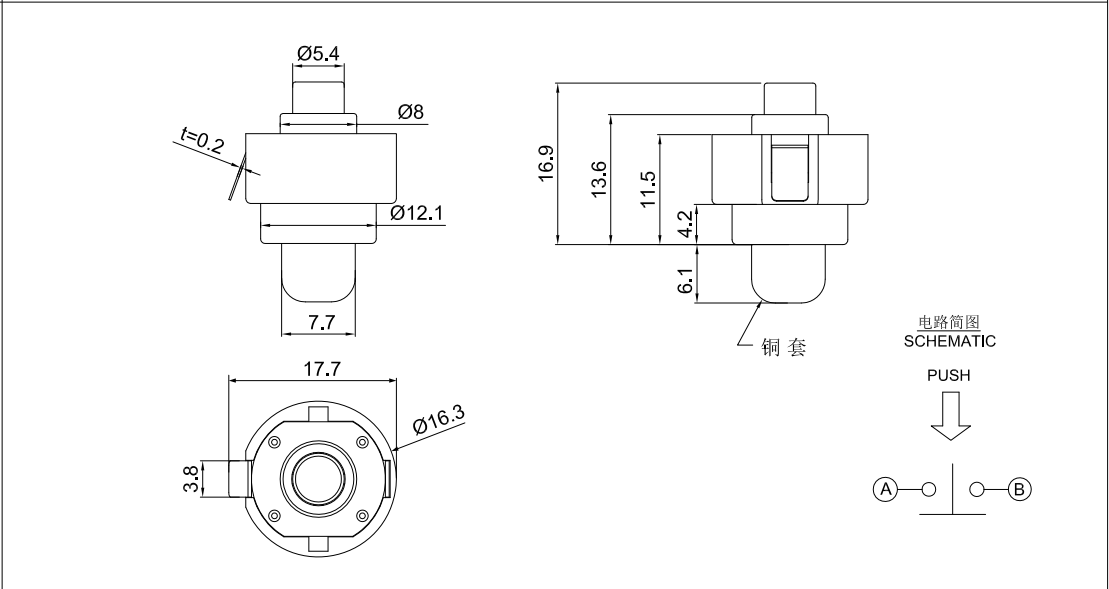
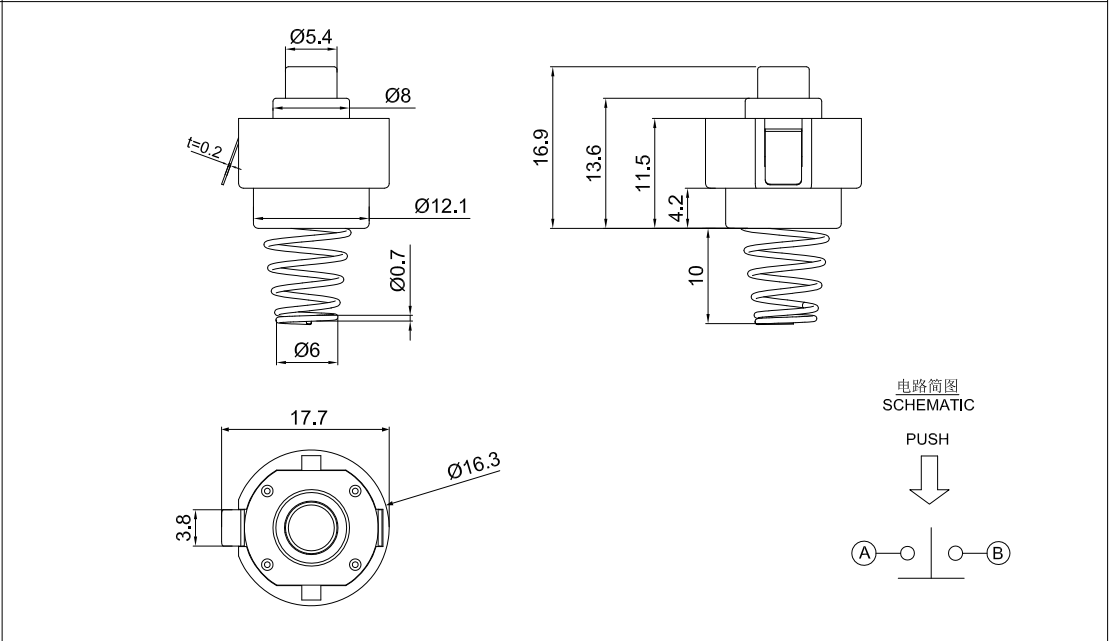
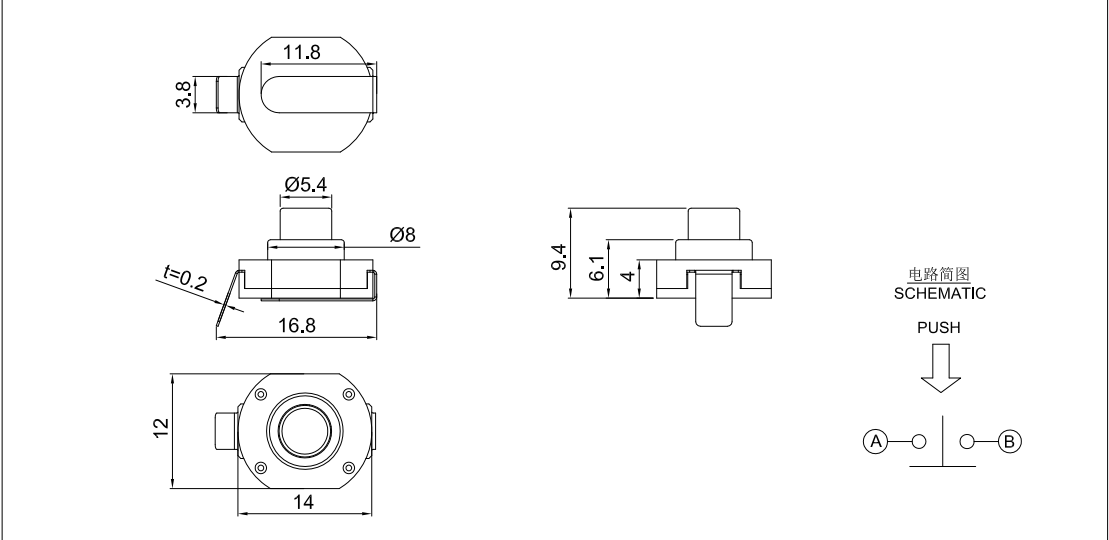



克力范围 Operating Force	700±100g	绝缘电阻 Insulation Resistance	≥ 100MΩ
额定电流、电压 Rating	AC 250V 5A	抗电强度 Dielectric Intensity	≥1500VAC/min
接触电阻 Contact Resistance	≤ 100mΩ	电器寿命 Electrical Life	≥20000 Cycles

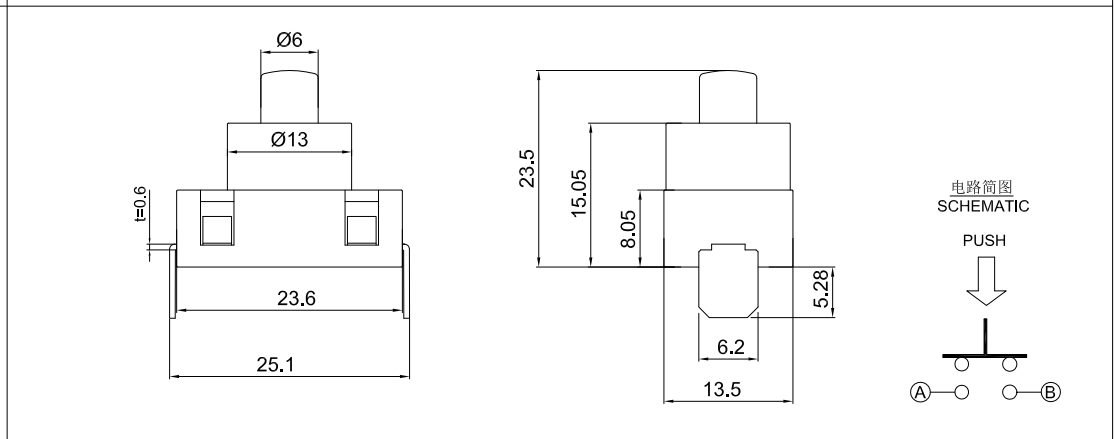
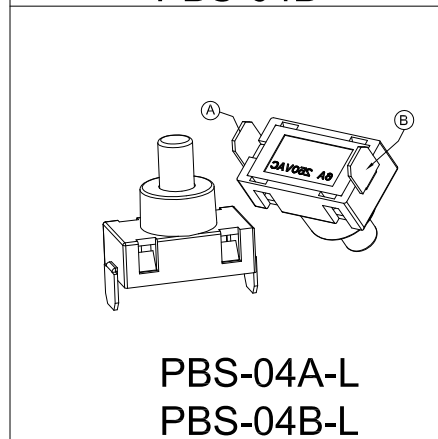
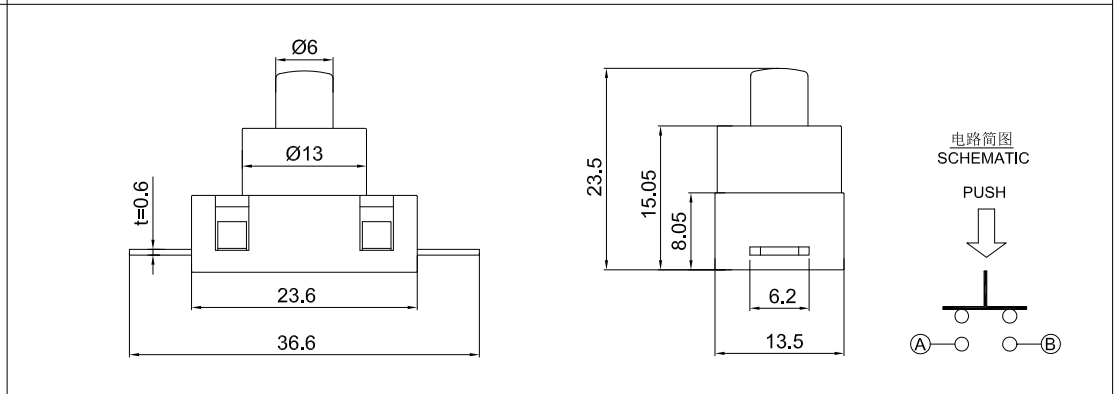
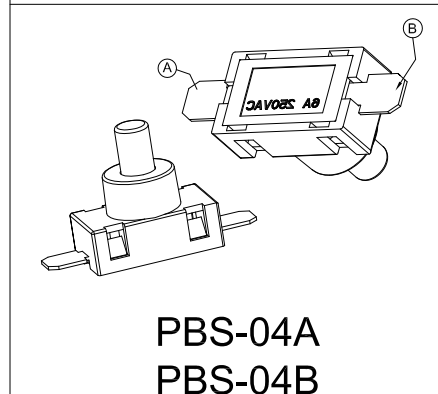
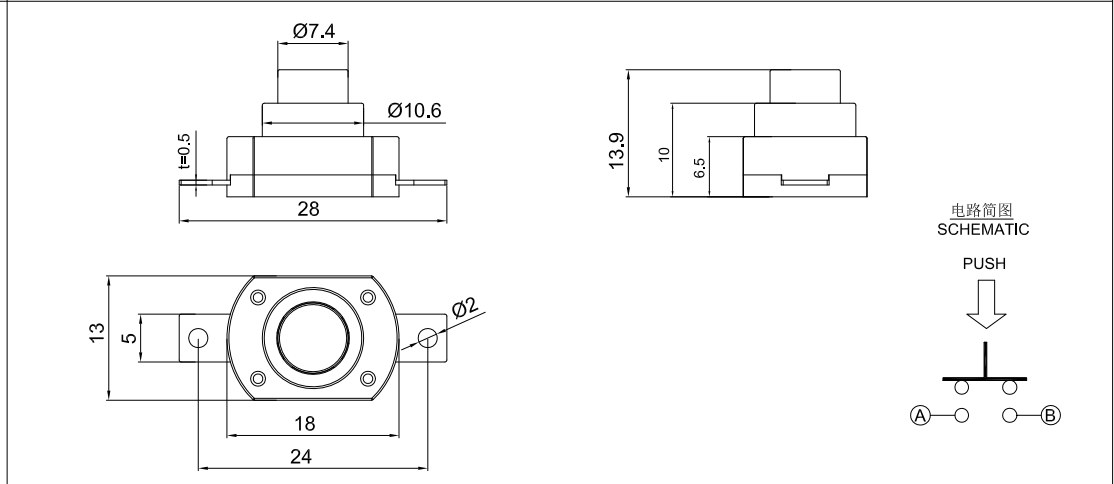
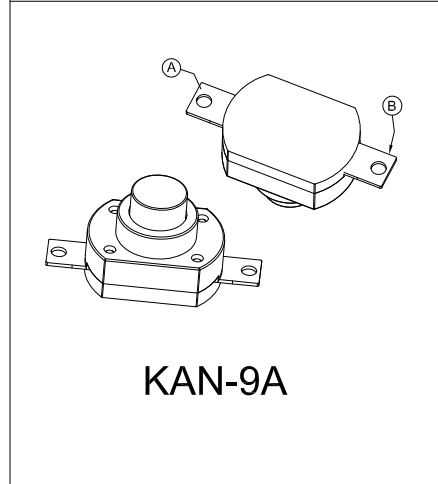
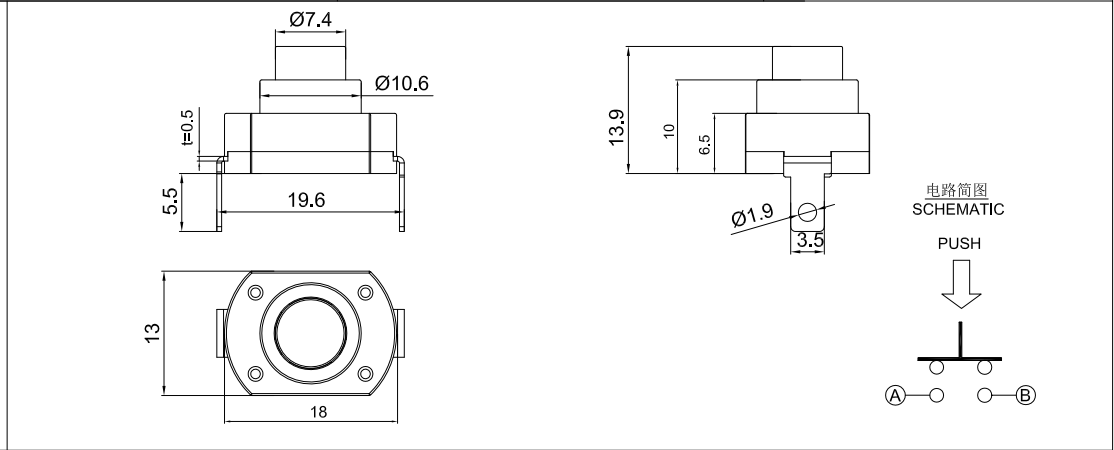
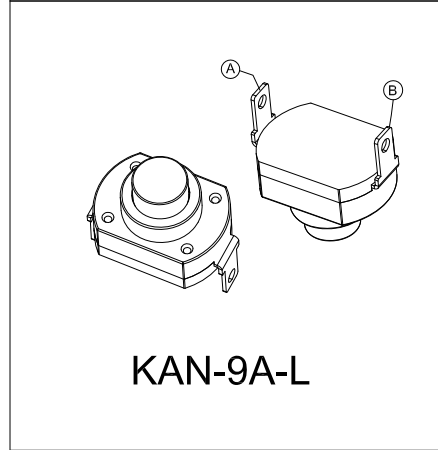

克力范围 Operating Force	700±100g	绝缘电阻 Insulation Resistance	≥ 100MΩ
额定电流、电压 Rating	DC 30V 1.5A	抗电强度 Dielectric Intensity	≥1500VAC/min
接触电阻 Contact Resistance	≤ 100mΩ	电器寿命 Electrical Life	≥20000 Cycles

